

NEW!



ATF X-DRIVE
02.023.65



ATF S-DRIVE
5000 02.023.50
4500 02.023.40



ATF 4000
PROFI 02.023.11
BASIC 02.023.10



ATF START
02.023.42



ATF RÈMIN
02.023.55



ATF 3000 PRO
02.022.70

NEW!

CARATTERISTICHE TECNICHE	X-DRIVE 4500 cod. 02.023.65	S-DRIVE 4500 cod. 02.023.40	S-DRIVE 5000 cod. 02.023.50	ATF 4000 BASIC cod. 02.023.10	ATF START cod. 02.023.42
Display a colori touch screen	Tablet 8" 4G Wi-Fi	✓ 5"	✓ 5"	-	-
Display grafico 240x64 monocromatico	-	-	-	✓	✓
Software a icone di immediata comprensione	✓	✓	✓	✓	✓
Software multilingue	✓	✓	✓	✓	✓
Pompa	1	1	2	2	1
Misura olio: 2 bilance elettroniche	✓	✓	✓	✓	✓
Misura pressione olio uscita cambio	✓	✓	✓	✓	✓
Misura pressione olio uscita ATF	✓	-	✓	✓	-
Funzione AWS: Correzione automatica peso specifico olio nuovo	✓	✓	✓	manual	manual
Funzione warm-up automatico (avvio del ciclo automatico al raggiungimento della temperatura minima ottimale)	✓	✓	✓	-	-
Lavaggio circuito di aspirazione olio nuovo	✓	✓	✓	-	-
Misura temperatura olio usato	✓	✓	✓	✓	✓
Kit dipstick	-	-	✓	✓	-
Iniezione additivo automatica	✓	✓	✓	✓	manuale guidata/ manual guided
Possibilità di operare in modo automatico o manuale	✓	✓	✓	✓	semiautomatico
Regolatore riduzione flusso in ingresso (integrato)	✓	-	-	-	-
Diagnosi integrata con messaggi e relativa guida per service	✓	-	-	-	-
Doppia alimentazione 12V DC e 220V AC con allarme batteria scarica e riconoscimento automatico della fonte di alimentazione	✓	-	-	-	-
Aggiornamento software e database via USB	WiFi / 4G	✓	✓	-	-
Flussimetri (old/new)	✓	✓ illuminati/ backlight	✓ illuminati/ backlight	✓ illuminati/ backlight	tubi trasparenti, 3 mt/ transparent hoses, 3 mt
Taniche olio nuovo/usato	2 x 20lt	2 x 20lt	2 x 30lt	2 x 30lt	2 x 20lt
Nuovo filtro sinterizzato riutilizzabile con magnete	✓ 2 filtri / filters	✓	✓	✓	✓
2 cassette raccordi e tubi vetture europee e asiatiche	✓	✓	✓	✓	✓
Stampante	✓	Optional	✓	Optional	Optional
Kit SmartPack (abbonamento per 12 mesi)	✓	✓	✓	✓	✓
Software cambio olio servosterzi con adattatori a richiesta	-	✓	✓	✓	-
Banca dati integrata con marca, versione, numero rapporti, tipo di cambio, quantità olio; il raccordo da usare e il tipo/marca di olio è inseribile da parte dell'utente	✓	✓	✓	-	-
Invertitore tubi direzione olio	Automatic (internal)	Optional (external)	Optional (external)	Optional (external)	Integrato Integrated



ATF REMIN cod. 02.023.55	ATF 3000 PRO cod. 02.022.70	TECHNICAL FEATURES
-	-	Color touch display 5"
-	-	Monochromatic graphic display 240x64
-	-	Software with icons easy to use
-	-	Multilingual software
1	1	Pump
visiva / visual	visiva / visual	Oil Measurement: 2 electronic scales
✓	✓	Gearbox's outlet oil pressure measurement
-	✓	ATF's outlet oil pressure measurement
-	-	AWS function: Automatic new oil specific weight correction
-	-	Automatic Warm-Up function (starting of the automatic cycle upon reaching the min. optimal temperature)
-	-	Washing of the new oil suction circuit
-	-	Measurement of the waste oil temperature
optional	✓	Dipstick kit
manuale guidata/ manual guided	manuale guidata/ manual guided	Automatic additive injection
manual	manual	Possibility to operate in automatic or manual mode
-	-	Input flow reduction regulator (built-in)
-	-	Integrated diagnosis with messages and related guide for the service
-	-	Dual 12V DC and 220V AC power supply with low battery alarm and automatic power source recognition
-	-	Software and database updatable via USB
✓	✓	Flowmeters (old/new)
2x20lt	2 x 25lt con illuminazione/ with led bar	New and waste oil tanks
✓	filtro olio classico/ classic oil filter	New sintered reusable filter with magnet
v	✓ KIT A+B	2 cases of couplings and hoses for European and Asiatic vehicles
-	-	Printer
✓	✓	Kit SmartPack (subscription for 12 months)
-	-	Software for power steering oil change with optional adapters
-	-	Integrated database with brand, version, number of ratios, gearbox type, oil quantity, oil code; the connection to be used and the oil type/brand can be inserted manually by the operator
Standard	Optional (external)	Oil flow hose inversion device (external)

ATF

Accessori INCLUSI STANDARD accessories

SmartPack ATF DATABASE

**FREE ACCESS
TO MORE THAN
4000 MODELS**

**ACCESSO
ALLA BANCA DATI
CAMBI AUTOMATICI
CON PIU' DI 4000 MODELLI**

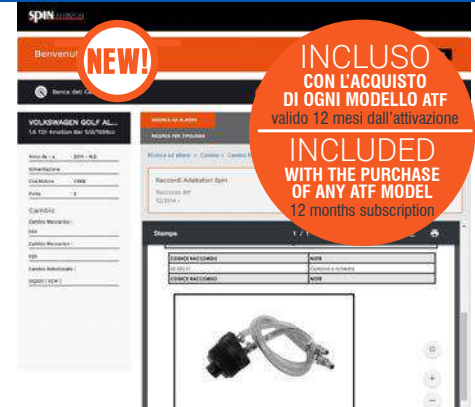

**INCLUSO
CON L'ACQUISTO
DI OGNI MODELLO ATF
valido 12 mesi dall'attivazione**

**INCLUDED
WITH THE PURCHASE
OF ANY ATF MODEL
12 months subscription**

**DOTAZIONE BASE INCLUSA NEI SEGUENTI MODELLI:
STANDARD COUPLINGS INCLUDED IN THE FOLLOWING MODELS:**

- ATF XDRIVE**
- ATF 4500**
- ATF 5000**
- ATF 4000**
- ATF START**
- ATF REMIN**



**DOTAZIONE BASE INCLUSA NEL MODELLO ATF 3000 PRO:
STANDARD COUPLINGS ONLY FOR ATF 3000 PRO:**

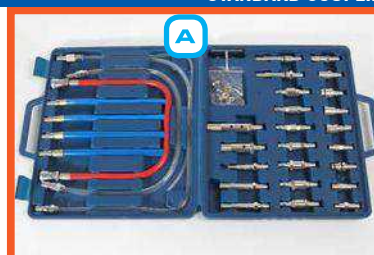

**DOTAZIONE BASE INCLUSA NEI SEGUENTI MODELLI:
STANDARD COUPLINGS INCLUDED IN THE FOLLOWING MODELS:**

ATF XDRIVE • ATF 5000 • ATF 4500 • ATF 4000 • ATF START • ATF REMIN



 <p>NEW!</p>		 <p>NEW!</p>		 <p>NEW!</p>	
<p>Cod. 02.022.11/new AISIN (Fiat Croma, Lancia Thesis, Renault Espace, Citroen C5/C3)</p>		<p>Cod. 02.022.21/new DSG</p>		<p>Cod. 02.022.52/new VOLVO V50</p>	
 <p>NEW!</p>		 <p>NEW!</p>			
<p>cod. 02.022.59/new BMW 8 MARCE/8 GEARS</p>		<p>cod. 02.022.98/new BMW 8 HP ZF</p>		<p>cod. 02.022.85/new DIPSTICK</p>	
					
cod. 02.022.33/new JAP/MB/LANCIA	cod. 02.022.30/new JAP/BMW	cod. 02.022.31/new JAP/GM	cod. 02.022.32/new JAP/GM	cod. 02.022.29/new JAP/ALFA ROMEO	cod. 02.022.34/new JAP/VOLVO
					
cod. 02.022.79/new JAP/MB/HUMMER/JEEP	cod. 02.022.84/new JAP/M14X1,5	cod. 02.022.37/new JAP/CITROEN/LANCIA	cod. 02.022.81/new JAP/1/8G	cod. 02.022.44/new BMW/MERCEDES 2001	cod. 02.022.80/new JAP/RUBBER HOSE FITTING/POR-TAGOMMA
					
cod. 02.022.07/.78/.45/new BMW 2010	cod. 02.022.09/new BMW 3 SERIES	cod. 02.022.18/new OPEL INSIGNA	cod. 02.022.63/new VW TIGUAN/PORSCHE 911	cod. 02.022.13/new AUDI Q5/Q7	cod. 02.022.99/new FIAT 500 X ZF
					
<p>Tubi per applicazioni generali / Hoses for general applications</p>		<p>Tubi per applicazioni generali / Hoses for general applications</p>		<p>Tubi per applicazioni generali / Hoses for general applications</p>	
<p>cod. 02.022.25/new (ø 8) x 2</p>		<p>cod. 02.022.26/new (ø 10)</p>		<p>cod. 02.022.27/new (ø 12)</p>	
				<p>cod. 02.022.28/new (ø 14)</p>	

SMART PACK ATF

ATF DATABASE ONLINE

**INCLUSO
CON L'ACQUISTO
DI OGNI MODELLO ATF**
valido 12 mesi dall'attivazione

**INCLUDED
WITH THE PURCHASE
OF ANY ATF MODEL**
12 months subscription



SPIN AUTOMOTIVE EXPERTISE

CAMBIO → CAMBIO AUTOMATICO → CIRCUITO IDRAGICO DI RAFFREDDAMENTO/RACCORDI

Dati Procedura	
Descrizione:	CAMBIO GA6HP192 dal 9/2004 al 3/2007
Mese/Anno:	

Dati Veicolo	
Veicolo:	BMW - Serie 1 (E81-E87) - 118d Ber. 5p/d/1995cc dal 09/2004 al 03/2007
Mese/Anno:	
Codice motore:	N47D20C

Dettagli Procedura

1) Tubazione di mandata dal cambio al radiatore. 2) Tubazione di ritorno dal radiatore al cambio.

Figura 1 Figura 2

SMART PACK ATF è un servizio di consultazione della banca dati che raccoglie informazioni tecniche riservate sui cambi automatici:

- Identificazione rapida del veicolo:
 - ricerca per marca, modello o codice motore
 - ricerca per marca veicolo o codice del cambio
 - ricerche tramite targa veicolo (5 ricerche incluse)*
- Ubicazione targhetta identificativa (A)
- Ubicazione componenti, procedure e adattamenti (B)
- Informazioni sull'adattatore da utilizzare per collegare il lavacambi ATF al cambio automatico (C)
- Circuito idraulico di raffreddamento
- Controllo livello olio
- Richiesta via mail di informazioni tecniche aggiuntive (10 interrogazioni incluse)*

**Servizio riservato solo per l'Italia*

SMART PACK ATF is a database consultation service that gathers confidential technical information on automatic transmissions:

- Quick vehicle identification:
 - search by brand, model or engine code
 - search by vehicle brand or gearbox code
- Location of identification plate (A)
- Location of components (B)
- Information on the adapter to be used to connect the ATF unit to the automatic transmission (C)
- Procedures and adaptations
- Cooling hydraulic circuit
- Oil level check

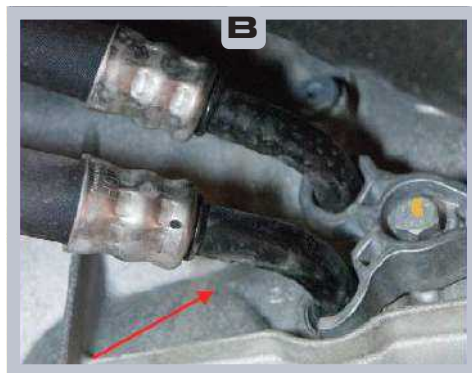
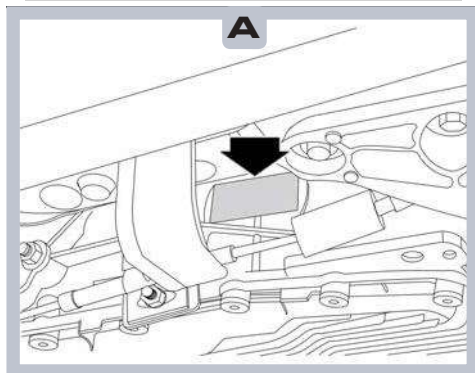

RINNOVO ANNUALE / ANNUAL RENEWAL

Cod. 02.022.110

SMART PACK ATF
ATF DATABASE ONLINE

NEW!

ATF XDRIVE

CONNECTION

COD. 02.023.65

Apparecchio per il lavaggio e sostituzione dell'olio nei cambi automatici con Tablet 8" estraibile per controllo delle funzioni da remoto (Bluetooth)

- Tablet 8" 4G Wi-Fi
- Consultazione diretta data base online (4G o Wi-Fi)
- Controllo remoto delle funzioni e visualizzazione delle operazioni in corso attraverso il tablet rimovibile dall'ATF
- Informazioni guidate per l'operatore
- Data base integrato
- Riconoscimento e inversione automatica del flusso dell'olio (elettronico)
- Regolatore riduzione flusso in ingresso (integrato)
- Diagnosi integrata con messaggi e relativa guida per service
- Procedura guidata per sostituzione tanica olio nuovo (possibilità di altre taniche a richiesta)
- Funzioni guidate per procedura lavaggio radiatore e sostituzione filtro
- Procedura specifica per DSG
- Doppia alimentazione 12V DC e 220V AC con allarme batteria scarica e riconoscimento automatico della fonte di alimentazione
- Stampante inclusa
- Accesso diretto all'olio esausto per svuotamento coppa
- Kit raccordi e tubi per vetture europee e asiatiche (pagina 20)

Oil exchanger for automatic transmissions with the removable 8" Tablet for the remote control of functions (Bluetooth)

- 8" 4G Wi-Fi Tablet
- Direct consultation of the database online (by 4G or Wi-Fi)
- Remote control of functions and monitoring of ongoing operations via the ATF's removable tablet
- Guided information for the user
- Integrated database
- Automatic oil flow recognition and inversion (electronically)
- Input flow reduction regulator (built-in)
- Integrated diagnosis with messages and related guide for the service
- Improved procedure for replacing new oil tank (other tanks on request)
- Guided functions for manual procedure
- Funzioni guidate for radiator washing procedure and filter replacement
- Specific procedure for DSG
- Dual 12V DC and 220V AC power supply with low battery alarm and automatic power source recognition
- Printer included
- Direct access to waste oil for pan emptying
- Kit of fittings and hoses for European and Asian cars

ATF XDRIVE
Cleaner & Oil Exchanger

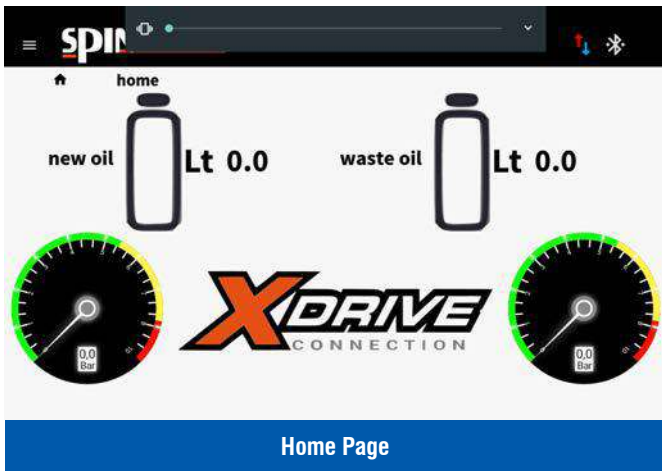

Home Page

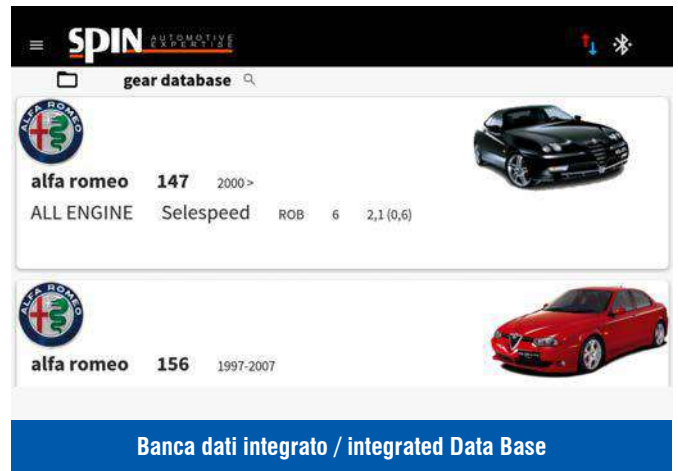

Banca dati integrato / integrated Data Base



Ciclo automatico / automatic cycle



Ciclo manuale / manual cycle



Settaggio parametri / Settings

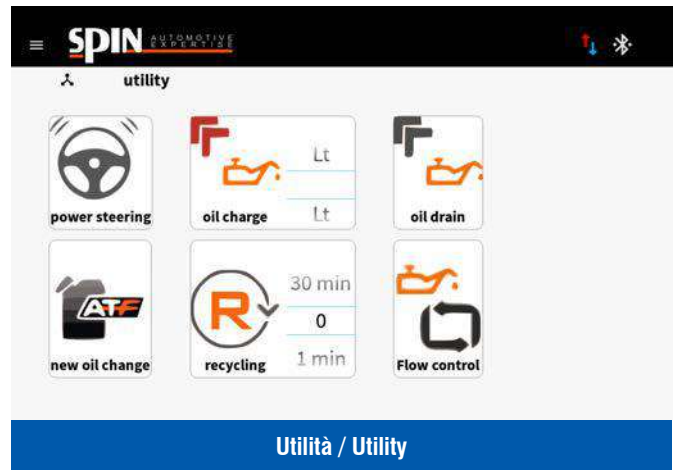

Utilità / Utility

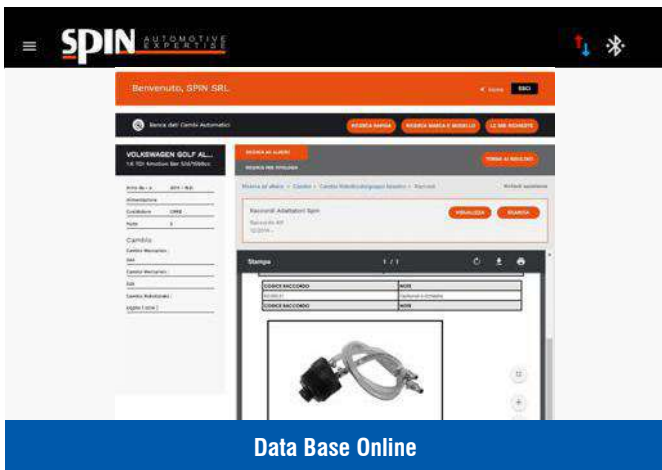

Data Base Online

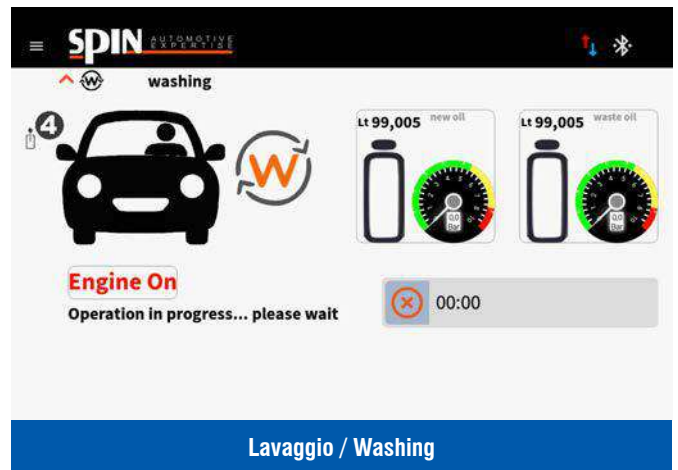

Lavaggio / Washing



> Le foto sono puramente indicative e possono essere cambiate senza preavviso.
 > The pictures have merely explanatory purposes and can be changed with no warning.

Atf SDRIVE 5000

IT

- **A:** Display a colori touch screen 5"
- **A:** Misura pressione olio uscita cambio
- **A:** Misura pressione olio uscita ATF
- **B:** Software a icone multilingue
- **C:** Funzione AWS: Correzione automatica peso specifico olio nuovo
- **D:** Funzione warm-up automatico (avvio del ciclo automatico al raggiungimento della temperatura minima ottimale)
- **E:** Lavaggio circuito di aspirazione olio nuovo
- **F:** Kit dipstick
- **G:** Iniezione additivo automatica
- **H:** Possibilità di operare in modo automatico o manuale
- **I:** Aggiornamento software e database via USB
- **J:** Flussimetri illuminati
- **K:** Tanciche olio nuovo/usato
- **L:** Nuovo filtro sinterizzato riutilizzabile con magnete
- **M:** Kit raccordi e tubi per vetture europee e asiatiche
- **N:** Stampante
- **O:** **SmartPack** (password per accesso gratuito per 12 mesi alla banca dati online)
- **P:** Software cambio olio servosterzi
- **Q:** Banca dati integrata con marca, versione, numero rapporti, tipo di cambio, quantità olio

EN

- **A:** 5" color touch display
- **A:** Gearbox outlet oil pressure measurement
- **A:** ATF's outlet oil pressure measurement
- **B:** Multilingual software
- **C:** AWS function: Automatic new oil Weight Set
- **D:** Funzione warm-up automatico (avvio del ciclo automatico al raggiungimento della temperatura minima ottimale)
- **E:** Washing of the new oil suction circuit
- **F:** Dipstick kit
- **G:** Automatic additive injection
- **H:** Possibility to operate in automatic or manual mode
- **I:** Software and database updatable via USB
- **J:** Flowmeters with backlight (old/new)
- **K:** New and waste oil tanks
- **L:** New sintered reusable filter with magnet
- **M:** Kit of couplings and hoses for European and Asiatic vehicles included
- **N:** Printer
- **O:** **SmartPack** (12 months of free access to the online Database)
- **P:** Software for power steering oil change
- **Q:** Integrated database with brand, version, number of ratios, gearbox type, oil quantity, oil code

ATF S-DRIVE 5000



S-DRIVE 5000

COD. 02.023.50



ATF SDRIVE

Cleaner & Oil Exchanger

S-DRIVE 5000

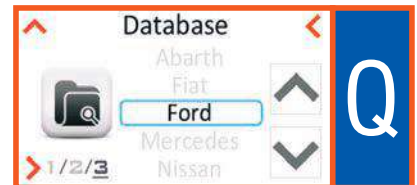
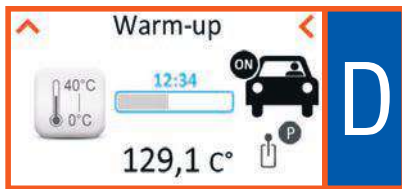

> Le foto sono puramente indicative e possono essere cambiate senza preavviso.
 > The pictures have merely explanatory purposes and can be changed with no warning.

Atf SDRIVE 4500

ATF S-DRIVE 4500



IT

- **A:** Display a colori touch screen 5'
- **A:** Misura pressione olio uscita cambio
- **B:** Software a icone multilingue
- **C:** Funzione AWS: Correzione automatica peso specifico olio nuovo
- **D:** Funzione warm-up automatico (avvio del ciclo automatico al raggiungimento della temperatura minima ottimale)
- **E:** Lavaggio circuito di aspirazione olio nuovo
- **F:** Nuovo filtro sinterizzato riutilizzabile con magneti
- **G:** Iniezione additivo automatica
- **H:** Possibilità di operare in modo automatico o manuale
- **I:** Aggiornamento software e database via USB
- **J:** Flussimetri illuminati
- **K:** Tanciche olio nuovo/usato
- **L:** Kit raccordi e tubi per vetture europee e asiatiche
- **M:** **SmartPack** (password per accesso gratuito per 12 mesi alla banca dati online)
- **N:** Software cambio olio servosterzi
- **O:** Banca dati integrata con marca, versione, numero rapporti, tipo di cambio, quantità olio

S-DRIVE 4500

COD. 02.023.40

EN

- **A:** Color touch display 5'
- **A:** Gearbox outlet oil pressure measurement
- **B:** Multilingual software
- **C:** AWS function: Automatic new oil Weight Set
- **D:** Funzione warm-up automatico (avvio del ciclo automatico al raggiungimento della temperatura minima ottimale)
- **E:** Washing of the new oil suction circuit
- **F:** New sintered reusable filter with magnet
- **G:** Automatic additive injection
- **H:** Possibility to operate in automatic or manual mode
- **I:** Software and database updatable via USB
- **J:** Flowmeters with backlight (old/new)
- **K:** New and waste oil tanks
- **L:** Kit of couplings and hoses for European and Asiatic vehicles included
- **M:** **SmartPack** (12 months of free access to the online Database)
- **N:** Software for power steering oil change
- **O:** Integrated database with brand, version, number of ratios, gearbox type, oil quantity, oil code



S-DRIVE 4500

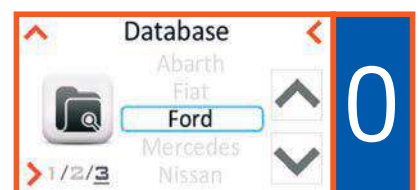
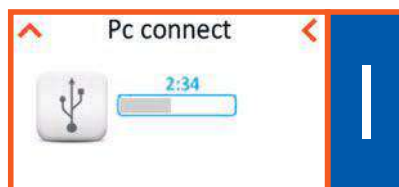

> Le foto sono puramente indicative e possono essere cambiate senza preavviso.
 > The pictures have merely explanatory purposes and can be changed with no warning.

Atf START

ATF START



ATF START

COD. 02.023.42

IT

- **A:** Display grafico 240x64
- **A:** Tastiera comandi con solo 4 tasti
- **A:** Software a icone di immediata comprensione
- Software intuitivo che si adatta ai differenti modi di operare dell'officina
- **B:** Software multilingue
- **A:** Misura della pressione di ritorno
- **C:** Selezione peso specifico olio (Kg/lit)
- 2 bilance elettroniche
- 1 pompa, 220V50Hz (110V60Hz a richiesta)
- Misura della temperatura dell'olio
- **D:** Possibilità di operare in modo manuale o completamente automatico
- **E:** Protezione da sovrappressioni con funzione "ricircolo automatico" a inizio e a fine carica
- **F:** Compensazione automatica lunghezza tubi
- **G:** Possibilità di aggiornamento software
- **H:** Iniezione additivo manuale
- **I:** Inversione tubi manuale (integrato) (J)
- **J:** Tubi trasparenti per il controllo flusso olio
- **K:** Cassetta raccordi e tubi vetture europee e asiatiche
- **L:** Taniche olio nuovo/usato da 20 lt rimovibili
- **M:** Nuovo filtro sinterizzato con magnete (riusabile)
- **N:** Predisposizione per stampante (fornita a richiesta)
- **O:** **SmartPack** (password per accesso gratuito per 12 mesi alla banca dati online)

EN

- **A:** Graphic display 240x64
- **A:** Control keyboard with only 4 buttons
- **A:** User-friendly software with icons
- Intuitive software that adapts to different operation mode of the workshop
- **B:** Multilingual software (22 languages)
- **A:** Measurement of the return pressure
- **C:** Selection of the oil specific weight (kg/lit)
- 2 electronic scales
- 1 pump, 220V50Hz (110V60Hz on request)
- Measurement of the oil temperature
- **D:** Possibility to operate in manual or full automatic mode
- **E:** Protection against overpressure with "automatic recirculation" at the beginning or end of charge
- **F:** Automatic length compensation of the hoses
- **G:** Possibility to update the software
- **H:** Manual additive injection
- **I:** Manual hose inversion device (built-in)
- **J:** Transparent hoses for the oil flow control
- **K:** Case of couplings and hoses for European and Asiatic vehicles
- **L:** Removable new/old oil tanks, capacity 20lt
- **M:** New sintered magnetic filter (reusable)
- **N:** Optional printer
- **O:** **SmartPack** (12 months of free access to the online Database)



ATF START

C l e a n e r & O i l E x c h a n g e r

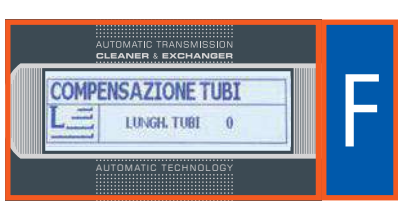
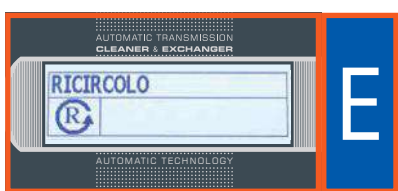
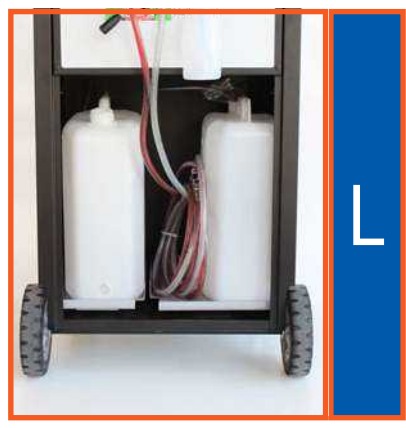
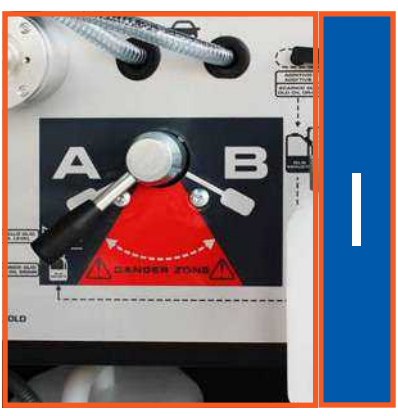
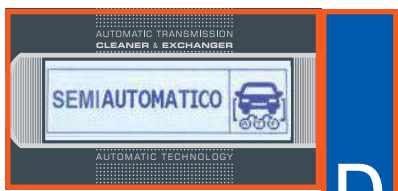
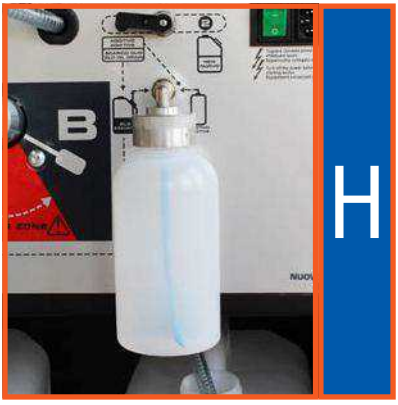
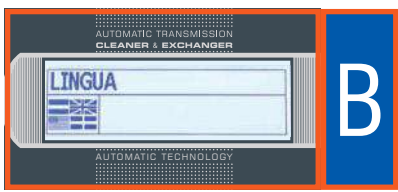

> Le foto sono puramente indicative e possono essere cambiate senza preavviso.
 > The pictures have merely explanatory purposes and can be changed with no warning.

Atf RÉMIN

manual

- IT**
- **A:** Pannello comandi con manometro olio usato, rubinetti/commutatori di fase e flussimetri
 - **B:** Kit raccordi e tubi per vetture europee e asiatiche (di serie)
 - **C:** **SmartPack** (password per accesso gratuito per 12 mesi alla banca dati online)
 - **D:** Iniettore additivo di 500ml con protezione contro manovre errate
 - **E:** Inversione tubi manuale (integrato)
 - **F:** Taniche olio nuovo/usato da 20 lt rimovibili
 - **G:** Nuovo filtro sinterizzato con magneti (riusabile)
 - **H:** Contaltri magnetici: Utili per il controllo visivo dei livelli (olio usato, olio nuovo)
 - **I:** Uso facilitato dell'apparecchio

- EN**
- **A:** Control panel with used oil pressure gauge, taps/phase switches and flowmeters
 - **B:** Kit of couplings and hoses for European and Asiatic vehicles (standard included)
 - **C:** **SmartPack** (12 months of free access to the online Database)
 - **D:** 500ml additive injector with protection against operational errors
 - **E:** Manual hoses inversion (integrated)
 - **G:** 20 liter removable oil containers for new/used oil
 - **G:** New sintered magnetic filter (reusable)
 - **H:** Magnetic litre-counters: Useful for visual control of the levels (used oil, new oil)
 - **I:** Facilitated use of the appliance

ATF RÉMIN
COD. 02.023.55

ATF RÉMIN SPIN USER'S GUIDE					
	A	B	C	ATF PUMP	CAR ENGINE
VERIFY THE PRESSURE PRESENCE ON THE GAUGE				OFF	ON
ADDITIVE INJECTION				ON	OFF
CLEANING				OFF	ON
EMPTY THE OIL PAN				OFF	ON
REMOVE THE OIL PAN				OFF	OFF
RADIATOR CLEANING				ON	OFF
FILTER CHANGE & OIL PAN REMOUNT				OFF	OFF
FILL THE PAN WITH NEW OIL				ON	OFF
OIL CHANGE IN THE TORQUE CONVERTER ADJUST SLOWLY THE TAP				ON	ON
RESTORE THE CONNECTION				OFF	OFF
OIL LEVEL CONTROL A				ON	OFF
USED OIL DISCHARGE A				ON	OFF

ATF RÉMIN
C l e a n e r & O i l E x c h a n g e r

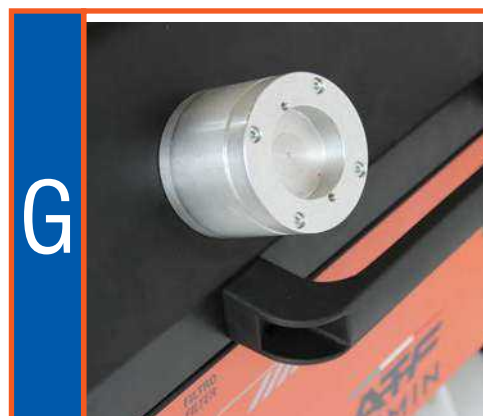
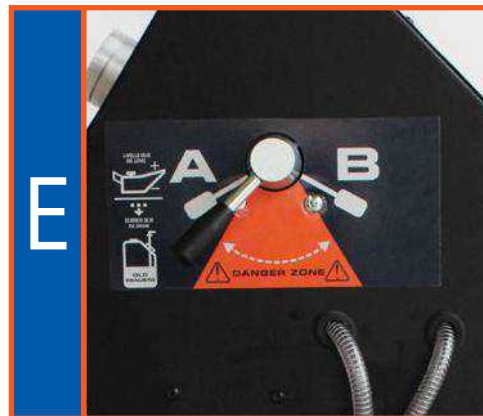
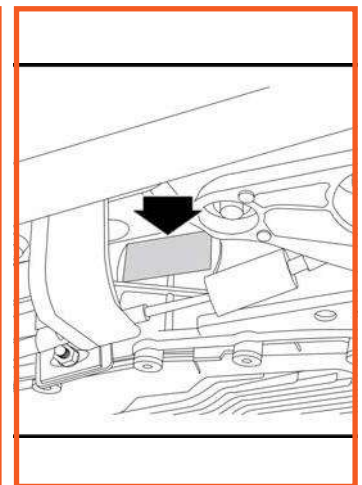
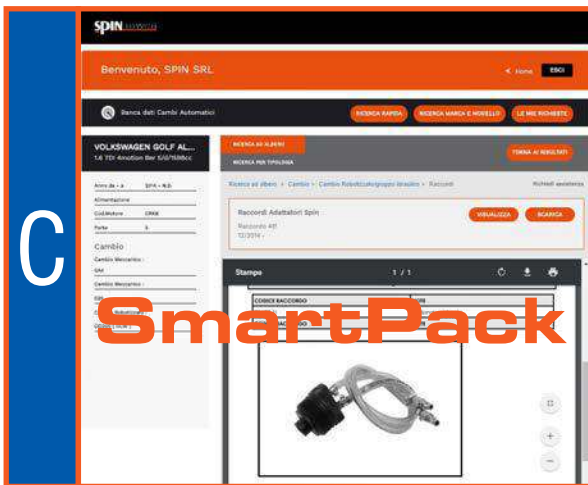
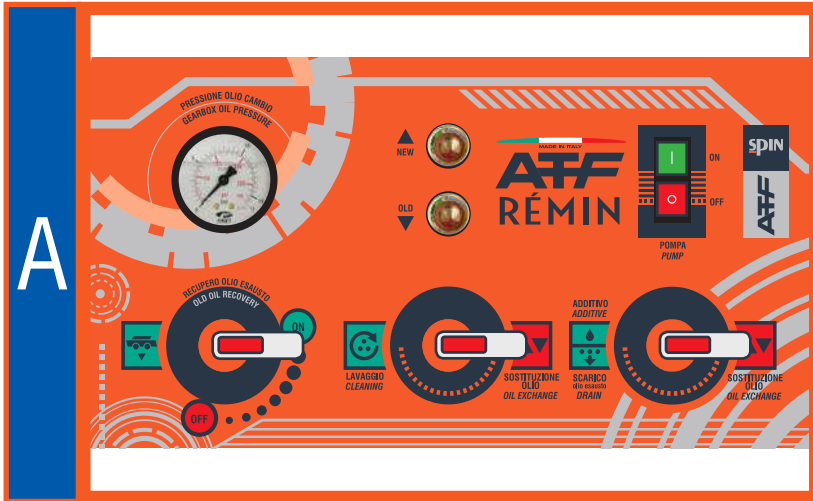

Atf 3000 PRO

manual



ATF 3000 PRO



IT

- **A:** Kit 1: Contiene i raccordi di vetture EU e Asiatiche <2001
- **B:** Kit 2: Contiene adattatori e raccordi di vetture dal 2002 al 2012
- **C:** Dipstick: Dispositivo per operare su cambi sigillati senza scambiatore o in caso di difficoltà di accesso ai punti di intersezione
- **D: SmartPack** (password per accesso gratuito per 12 mesi alla banca dati online)
- **E:** Contaltri magnetici: Utili per il controllo visivo dei livelli (olio usato, olio nuovo)
- **F:** Versione 220V con interruttore generale e protezione da cortocircuito e sovraccarichi
- **G:** Illuminazione taniche interne: Essenziale per il controllo visivo dei diversi tipi di oli ATF in tanica
- **H:** Iniettore additivo di 500ml con protezione contro manovre errate
- **I:** Nuove ruote con maggior piano di appoggio per agevolata movimentazione

EN

- **A:** Kit 1: It contains the fittings of EU and Asian cars dated <2001
- **B:** Kit 2: it contains adapters and fittings for cars from 2002 to 2012
- **C:** Dipstick: Device for operating on sealed gearboxes without heat exchanger or in case of difficult access to points of intersection
- **D: SmartPack** (12 months of free access to the online Database)
- **E:** Magnetic liters' counters: Useful for visual control of the levels (used oil, new oil)
- **F:** 220V version with power switch and protection against short circuits and overloads
- **G:** Lighting of the internal tanks: Essential for the visual control of the different types of ATF oils in the tank
- **H:** 500ml additive injector with protection against mishandling
- **I:** New wheels with larger supporting surface for easier movements

ATF 3000 PRO

COD. 02.022.70







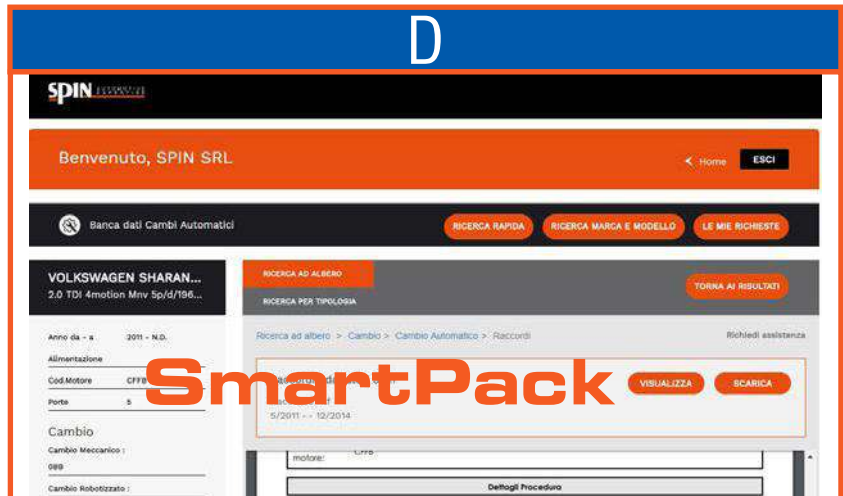
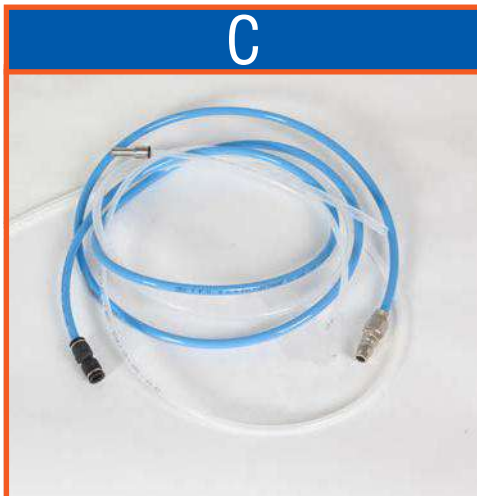
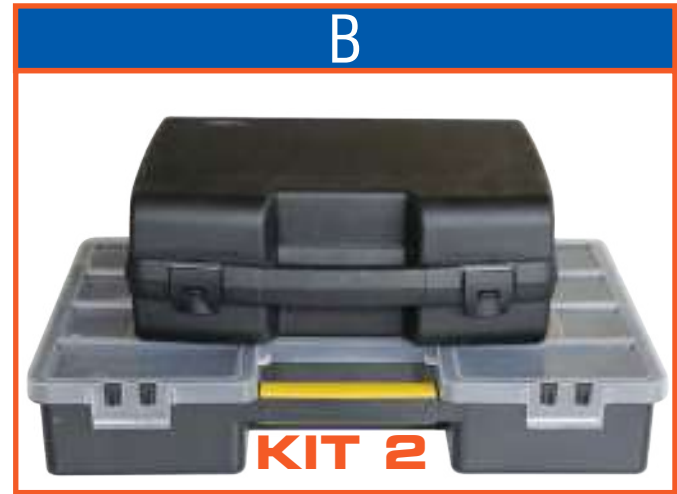
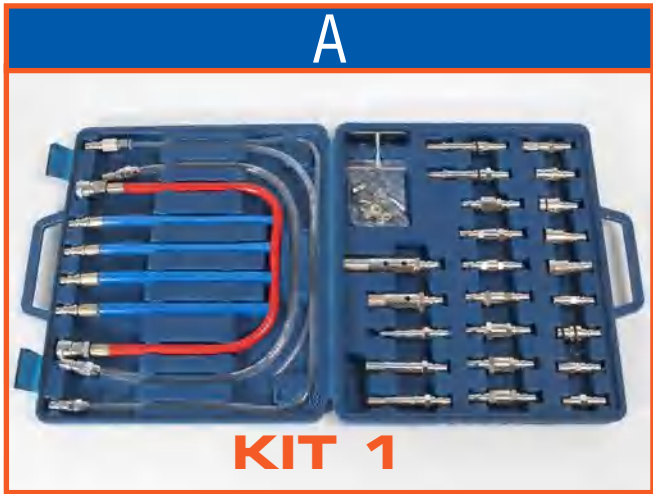



















ATF 3000 PRO











C l e a n e r & O i l E x c h a n g e r



> Le foto sono puramente indicative e possono essere cambiate senza preavviso.
 > The pictures have merely explanatory purposes and can be changed with no warning.

* 02.022.21/new		>Kit adattatore per filtri cambi DSG con 2 prolunghe >Adapter kit for filter of DSG transmissions, with 2 extenders		02.022.93/new		>Kit raccordi per Audi 4/6 Avant >2012, cambio 4G5 su scambiatore >Adapter kit for Audi 4/6 Avant >2012 (4G5) on oil exchanger	
* 02.022.11/new		>Kit adattatori per cambi AISIN >Adapter kit for AISIN (Fiat Croma, Lancia Thesis, Renault Espace, Citroen C5/C3)		02.022.94/new		>Kit adattatori per Mercedes Benz , cambio 722.9 >Adapter kit for Mercedes Benz, 722.9 gearbox	
* 02.022.52/new		> Kit adattatori per Volvo V50 >Adapter kit for Volvo V50		02.022.95/new		>Kit adattatori per TF80 MULTI >Adapter kit for TF80 MULTI gearboxes (Volvo, Alfa Romeo, Cadillac, Ford, Land Rover)	
* 02.022.59/new		>Kit per BMW 8 marce >Kit for BMW with 8 gears		02.022.97/new		> Kit adattatore Mercedes Classe A/B , cambio DCT > Adapter kit for Mercedes-Benz A-Class & B-Class, DCT gearbox	
* 02.022.98/new		> Kit per BMW 8 marce ZF > Kit for BMW with 8 gears, ZF		02.022.100		> Raccordo scambiatore olio/acqua cambio Toyota Avensis K311 da usare con tubi gomma Ø8 cassetta standard > Coupling for oil/water exchanger Toyota Avensis K311 gearbox to be used with rubber hoses Ø8 from standard case	
* 02.022.99/new		> Iniesto per FIAT 500X , cambio ZF > Adapter for FIAT 500X, ZF		02.022.101		> Raccordo scambiatore aria/olio cambio Toyota Corolla da usare con tubi gomma Ø8 cassetta standard > Coupling for oil/water exchanger Toyota Corolla gearbox to be used with rubber hoses Ø8 from standard case	
02.022.61/new		>Kit adattatori per cambi Powershift (Volvo - Ford Focus) >Adapter kit for Powershift gearbox (Volvo - Ford Focus)		02.022.102		> Raccordo scambiatore aria/olio cambio Mazda CX-5 (6 AT) da usare con tubi gomma Ø8 cassetta standard > Coupling for oil/water exchanger Mazda CX-5 (6 AT) gearbox to be used with rubber hoses Ø8 from standard case	
02.022.62/new		>Blocchetto per Mercedes CLK >Block for Mercedes Benz CLK		02.022.104		> Raccordo scambiatore olio/acqua cambio Nissan CVT (JF011E/REOF10A) > Coupling for oil/water exchanger Nissan CVT (JF011E/REOF10A)	
02.022.65/new		>Kit raccordi BMW 330D 180Hp >Adapter kit for BMW 330D 180Hp		02.022.105		> Raccordo scambiatore olio/acqua cambio Nissan 6CVT > Coupling for oil/water exchanger Nissan 6CVT	
02.022.72/new		> Kit adattatore Jatco per Nissan/Renault/Jeep/Mitsubishi > Adapter kit Jatco for Nissan/Renault/Jeep/Mitsubishi		02.022.107/new		> Kit raccordi per Maserati > Adapter kit for Maserati	
02.022.73/new		>Kit per Renault-Nissan <2003 , cambi DPO >Kit for Renault - Nissan <2003, transmissions DPO		02.022.108		> Kit piastra per Citroen C4/C5 PICASSO > Adapter kit for Citroen C4/C5 PICASSO	
02.022.74/new		>Staffa speciale per Audi A8 >Special adapter for Audi A8					
02.022.86/new		>Kit raccordi Volvo XC90 >Adapter kit for Volvo XC90					
02.022.88/new		>Kit per Porsche Cayenne / VW Touareg / Audi Q8 >Kit for Porsche Cayenne / VW Touareg / Audi Q8					

* Includi nella dotazione standard di ogni ATF / Included as standard accessories with the purchase of any ATF model

NEW! 02.022.109/new		> Kit piastra Renault Espace > Adapter kit for Renault Espace Applicazione/application: RE0F06A	NEW! 02.022.122/new		> Kit ATF Range Rover 4.2 > Adapter kit for Range Rover 4.2
02.022.116		> Kit adattatore LAND ROVER > Adapter kit for LAND ROVER Applicazione/application: 7F09HP	NEW! 02.022.124/new		> Kit ATF Volvo V70 > Adapter kit for Volvo V70
02.022.117		> Kit adattatore PEUGEOT 3800 > Adapter kit for PEUGEOT 3800	NEW! 02.022.126/new		> Kit ATF Ford Range 3.2/Mazda B-Series > Adapter kit for Ford Range 3.2/Mazda B-Series
02.022.120		> Kit piastra BMW/Mini/Volvo > Adapter kit BMW/Mini/Volvo Applicazione/application: AWF8F45 (TG-81LS)	NEW! 02.022.131		> Kit ATF Škoda > Adapter kit for Škoda
NEW! 02.022.121/new		> Perno ATF Audi SQ5 2013 > ATF adapter for Audi SQ5 2013	NEW! 02.022.132		> Kit ATF VW Polo > Adapter kit for VW Polo



Cod. 02.000.62/new
> Kit per vetture USA/Giappone
> Kit for USA/Japan vehicles
(Ford, Cadillac, Toyota, Nissan, Chrysler Jeep, GM, Dodge, Honda, Chevrolet, Chevy Duramax)



Cod. 02.022.04
> Kit 2 aste livello olio Mercedes Classe A e C
> Kit 2 oil level dipstick Mercedes A-Class & C-Class



Cod. 05.090.82
> Attrezzo per lo scarico e il rabbocco dell'olio nei cambi automatici **Mercedes Benz 9G - Tronic**
> Tool for draining and top up of oil in automatic gearboxes of **Mercedes Benz 9G - Tronic**



Cod. 02.022.66/new
> Rabboccatore livello olio
> Oil level refiller



Cod. 02.022.57/new
> Kit adattatori e tanica per cambio olio servosterzi
> Adapter kit and tank for oil change in the power steering



Cod. 05.088.21
> Carrello di servizio per accessori ATF
> Service trolley for ATF accessories

> **Additivo per ATF**
> **ATF additive**



Cod. 02.000.51
> Additivo per il lavaggio, 350 ml
> Flushing additive, 350 ml



Cod. 02.000.67
> Additivo per il lavaggio, tanica da 5 lt
> Flushing additive, 5 lt