

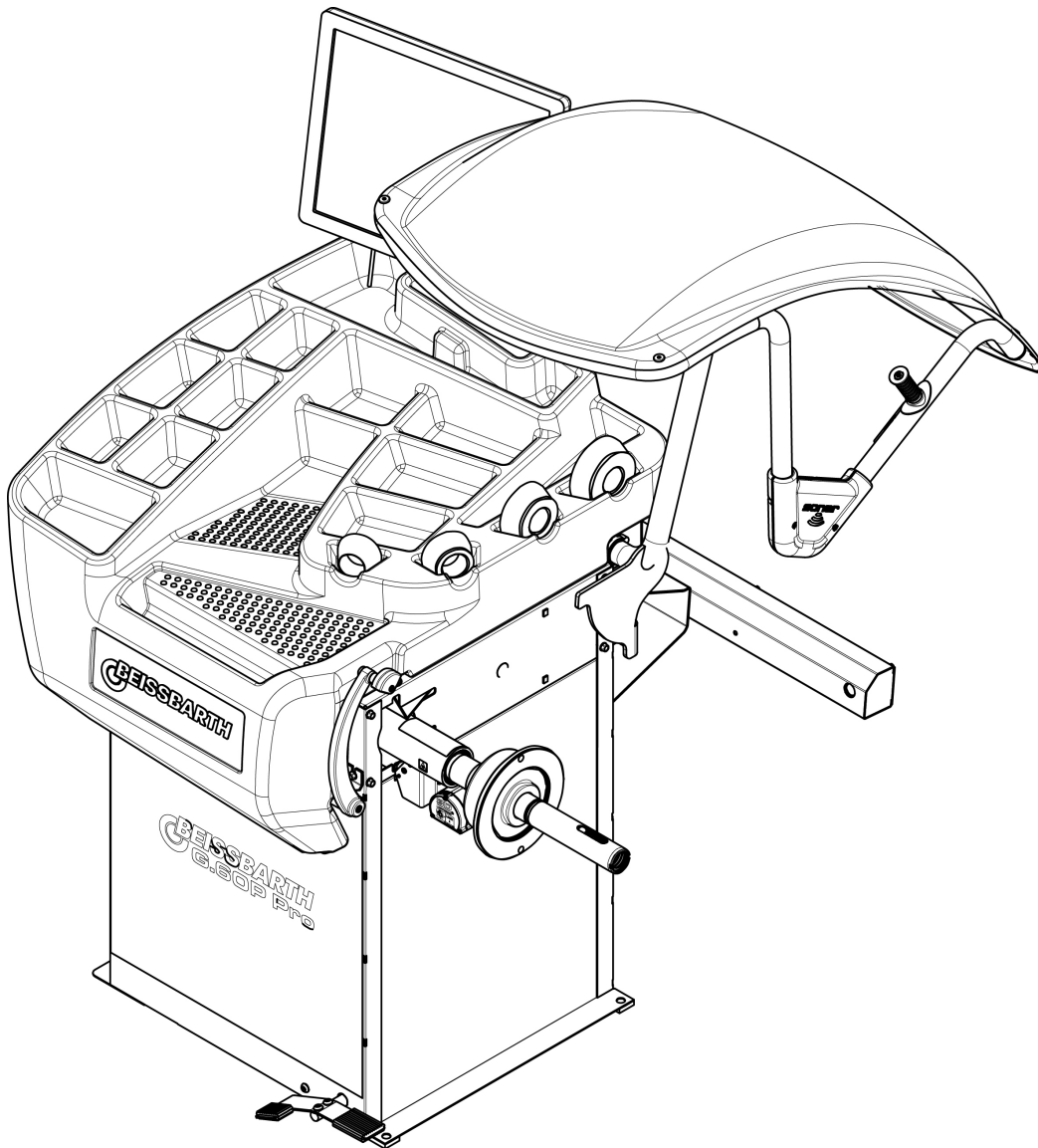

EN *Use and maintenance manual*



G.60P PRO

Beissbarth Automotive Testing Solutions GmbH
Hanauer Straße 101
80993 München
Phone: +49-89-14901-0 Mail: sales@beissbarth.com

The Manufacturer declines all liability for any damage to people or property caused by incorrect use of this product.
Subject to change without prior notice.



Istruzioni originali

Translation of the original instructions

Traduction de la notice originale

Übersetzung der Originalanweisungen

Traducción de las instrucciones originales

Tradução das instruções originais



EN Use and maintenance manual

General Index

1. FOREWORD	3
1.1 GENERAL	3
1.2 PURPOSE OF THE MANUAL	3
1.3 WHERE AND HOW TO KEEP THE MANUAL	4
1.4 MANUAL UPGRADES	4
1.5 COLLABORATION WITH USERS	4
1.6 MANUFACTURER	4
1.7 MANUFACTURER'S RESPONSIBILITY AND WARRANTY	4
1.7.1 Terms of warranty	5
1.8 TECHNICAL ASSISTANCE SERVICE	5
1.9 COPYRIGHT	5
2. MACHINE DESCRIPTION	6
2.1 TECHNICAL SPECIFICATIONS	6
2.2 DIMENSIONS	6
2.3 COMPONENTS	6
2.4 CLEANING INTERNAL LASERSCAN	7
3. STARTING	8
4. CORRECTION PLANE IDENTIFICATION	10
5. USE OF THE WHEEL BALANCER	11
5.1 INITIAL SCREEN	11
5.2 WHEEL DIMENSIONS SETTING	11
5.2.1 Result of the measurement and clip-on weight application	13
5.2.2 Result of the measurement and adhesive weight application (alu)	15
5.3 BALANCING WITH A MIX OF ADHESIVE AND CLIP-ON WEIGHTS (STATIC BALANCING)	16
5.4 STATIC UNBALANCE	17
5.5 OPB (ONE PLANE BALANCING)	18
5.6 HIDE THE ADHESIVE WEIGHTS (SPLIT)	19
5.7 AUTOMATIC MINIMIZATION OF STATIC UNBALANCE	19
5.8 UNBALANCE OPTIMIZATION	20
5.9 SETTING DIMENSIONS OF THE CORRECTION PLANES	20
5.10 WHEEL ECCENTRICITY MEASUREMENT AND OPTIMISATION	21
5.10.1 Wheel eccentricity measurement	21
5.10.2 Matching	22
5.10.2.1 How to perform matching	22
5.11 ECCENTRICITY AND MATCHING: THEORY	23
5.11.1 Presetting of tolerance on the machine	24
5.11.2 Value of static unbalance, correlated with eccentricity	24
5.11.3 Value of unbalance corresponding to eccentricity	24
6. MENU	25
6.1 MENU ACCESS DIAGRAM	25
6.2 STATISTICS	26

6.2.1	<i>Weight statistics screen</i>	26
6.3	CALIBRATIONS	27
6.3.1	<i>Sensors calibration</i>	27
6.3.1.1	<i>Width sonar calibration</i>	27
6.3.1.2	<i>Internal laser calibration</i>	27
6.3.2	<i>Balancing machine calibration</i>	28
6.3.3	<i>Adhesive weight width</i>	28
6.3.4	<i>Runout Setup</i>	28
6.3.5	<i>Loading laser board firmware</i>	28
6.3.6	<i>Touch screen calibration</i>	28
7.	SETUP	29
7.1	LANGUAGE	29
7.2	SCREEN-SAVER TIME	29
7.3	ACOUSTIC SIGNAL	29
7.4	SETTING THE CLOCK	29
7.5	OPTIONS	29
7.5.1	<i>Runout setup</i>	29
7.5.3	<i>Wheel locking enable</i>	30
7.5.4	<i>Wheel positioning</i>	30
7.5.5	<i>Tyre train</i>	30
7.5.6	<i>Weight statistics</i>	31
7.5.7	<i>Date</i>	31
7.5.8	<i>Time</i>	31
7.5.9	<i>LT automatic</i>	31
7.5.10	<i>Power-on screensaver</i>	31
7.5.11	<i>Inside laser at 12 o'clock</i>	31
7.5.12	<i>Outside laser at 12 o'clock</i>	31
7.6	BALANCING SETUP	31
7.6.1	<i>Unit of unbalance measurement</i>	31
7.6.2	<i>Unbalance display pitch</i>	31
7.6.3	<i>Tolerance</i>	31
7.6.4	<i>AUTOADAPTIVE correction method</i>	32
7.6.5	<i>Static always enabled</i>	32
7.6.6	<i>Automatic OPB selection</i>	32
7.7	SPECIAL FUNCTIONS	32
7.7.1	<i>Presetting the customer and user name</i>	32
7.7.2	<i>Wheel balancing machine SELF TEST</i>	32
8.	DIAGNOSTICS	33
8.1	INCONSISTENT UNBALANCE READINGS	33
9.	MAINTENANCE	36
9.1	GENERAL	36
9.1.1	<i>Introductory notes</i>	36
9.1.2	<i>Safety rules</i>	36
9.1.3	<i>Replacing fuses</i>	37
9.1.4	<i>Cleaning the screen</i>	37
10.	DISPOSAL	37
10.1	DISPOSING OF THE BALANCER	37
10.2	DISPOSING OF ELECTRONICS COMPONENTS	37
11.	SPARE PARTS	38
11.1	IDENTIFICATION AND ORDERING METHOD	38
12.	ATTACHED DOCUMENTATION	38

1. Foreword



THIS MANUAL IS AN INTEGRAL PART OF THE INSTALLATION MANUAL WHICH SHOULD BE CONSULTED CONCERNING STARTING AND USING THE MACHINE SAFELY.
READ CAREFULLY BEFORE CONTINUING.

1.1 GENERAL

The machine has been constructed in conformity with the current EC Directives and the technical standards implementing the requirements, as stated in the declaration of conformity issued by the manufacturer and attached to the manual.

This publication, hereinafter simply referred to as '**manual**', contains all the information required to safely use and service the machine referred to in the Declaration of Conformity.

This appliance, hereinafter is generically referred to as '**machine**'.

The manual addresses operators instructed on the precautions to take in relation to the presence of electric current and moving devices.

This publication is intended for all 'users' who as far as within their competence need to and/or are obliged to give instructions to others or operate on the machine themselves.

These persons can be identified as follows:

- operators directly involved in transporting, storing, installing, using and servicing the machine from when it is put on the market until when it is scrapped
- direct private users.

The original Italian text of this publication constitutes the only reference to resolve any interpretation controversies related to the translation into the European Community languages.

This publication forms an integral part of the machine and must therefore be kept for future reference until final dismantling and scrapping of the machine.

1.2 PURPOSE OF THE MANUAL

This manual, and the installation manual, contains the instructions required to use the machine safely and carry out routine maintenance work.

Any calibrations, adjustments and extraordinary maintenance operations are not considered in this document as they may only be performed by the service engineer who must work on the machine according to the technical and rated characteristics for which it was built.

Though it is fundamental to read this manual, it cannot replace skilled technical staff who must be adequately trained beforehand.

The foreseen use and configurations of the machine are the only ones allowed by the manufacturer; do not attempt to use the machine in a different way.

Any other use or configuration must be agreed in advance with the manufacturer in writing and in this case an annex will be attached to this manual.

For use, the user must also comply with the specific workplace legislation in force in the country where the machine is installed.

The manual also refers to laws, directives, etc., that the user must know and consult in order to accomplish the goals that the manual sets out to achieve.

1.3 WHERE AND HOW TO KEEP THE MANUAL

This manual (and relative attachments) must be kept in a safe and dry place and must always be available for consultation.

Make a copy and keep it in the archive.

When exchanging information with the manufacturer or the technical assistance staff authorised by the former, quote the rating plate information and the serial number of the machine.

This manual must be kept for the entire lifetime of the machine, and if necessary (e.g.: damage making all or some of it illegible, etc.) the user must request another copy exclusively from the manufacturer, quoting the publication code indicated on the cover.

1.4 MANUAL UPGRADES

This manual is an integral part of the machine and reflects the state of the art at the moment it was put on the market. The publication complies with the directives in force on that date; the manual cannot be considered inadequate as a result of regulatory updates or modifications to the machine.

Any manual upgrades that the manufacturer may see fit to send to users will become an integral part of the manual and must be kept together with it.

1.5 COLLABORATION WITH USERS

The manufacturer will be pleased to provide its customers with any further information they may require and will consider proposals for improving this manual in order to more fully satisfy the requirements it was written for.

In case of transfer of ownership of the machine, which must always be accompanied by the use and maintenance manual, the original user must inform the manufacturer of the name and address of the new user in order to allow it to send the new user any communications and/or updates deemed to be indispensable.

This publication is the property of the Manufacturer and may not be fully or partly reproduced without prior written agreement.

1.6 MANUFACTURER

The machine identification data is indicated on the plate mounted on the machine.

The plate below is shown for the sake of example.

MODEL	<input type="text"/>	VER	<input type="checkbox"/>
SER. N°	<input type="text"/>		
<input checked="" type="checkbox"/> V	<input type="text"/>	CE	KW <input type="text"/>
<input type="checkbox"/> A	<input type="text"/>		Hz <input type="text"/>
PHASE	<input type="text" value="1"/>	T° [C]	<input type="text"/>
	AIR SUPPLY Kg/cm ²		<input type="text"/>
<input type="text"/>			

1.7 MANUFACTURER'S RESPONSIBILITY AND WARRANTY

In order to make use of the manufacturer's warranty, the user must scrupulously observe the precautions contained in the manual, in particular he must:

- never exceed the limits of use of the machine
- always constantly and carefully clean and service the machine
- have the machine used by people of proven capacity and attitude, adequately trained for the purpose.

The manufacturer declines all direct and indirect liability caused by:

- use of the machine in a different way from that indicated in this manual
- use of the machine by people who have not read and fully understood the contents of this manual
- use in breach of specific regulations in force in the country of installation
- modifications made to the machine, software and operating logic, unless authorised by the manufacturer in writing
- unauthorised repairs
- exceptional events.

Transfer of the machine to a third party must also include this manual; failure to include the manual automatically invalidates all the rights of the purchaser, including the terms of warranty, where applicable.

If the machine is transferred to a third party in a country with a different language from the one written in this manual, the original user shall provide a faithful translation of this manual in the language of country in which the machine will operate.

1.7.1 Terms of warranty

The Manufacturer guarantees the machines it manufactures against all manufacturing or assembly faults for 12 (twelve) months from the date of collection or delivery.

The Manufacturer undertakes to replace or repair any part which it deems to be faulty free of charge at its factory, carriage paid.

If a Manufacturer's repairman (or a person authorised by the same) is required to work at the user's facilities, the relative travel expenses and board and lodging shall be charged to the user.

The free supply of parts under warranty is always subject to the faulty part being inspected by the manufacturer (or a person authorised by the same).

The warranty is not extended following repairs or other work done to the machine.

The warranty does not cover damage to the machine deriving from:

- transport
- neglect
- improper use and/or use not in compliance with the instructions in the operating manual
- incorrect electrical connections.

The warranty is invalidated in case of:

- repairs made by people who were not authorised by the manufacturer
- modifications that were not authorised by the manufacturer
- use of parts and/or equipment that were not supplied or approved by the manufacturer
- removal or alteration of the machine identification plate.

1.8 TECHNICAL ASSISTANCE SERVICE

For any technical service operation, contact the manufacturer directly or an authorised dealer always quoting the model, the version and the serial number of the machine.

1.9 COPYRIGHT

The information contained in this manual may not be disclosed to third parties. Partial or total duplication, unless authorised by the Manufacturer in writing, through photocopying, duplication or other systems, including electronic acquisition, is breach of copyright and can lead to prosecution.

2. Machine description

It is used to balance the wheels of cars, vans, 4-WD, motorcycles and scooters. The wheels must weigh less than 75 kg. and, when fitted on the balancing machine, must not interfere with any fixed part of the machine, excluding the shaft and support adaptor. The machine is supplied with equipment enabling the vast majority of car wheels available on the market to be fitted. Other wheels with special dimensions, geometry and centring require special adaptors supplied on request (consult the attached sheet “ORIGINAL ADAPTORS”). The machine can operate only on flat non resilient floor.

Do not mount anything other than motorbike, car or truck tyres on the wheel balancer.

Thanks to the new and exclusive VDD (Virtual Direct Drive - **CEMBPATENT**) system, reliable unbalance measurements can be made in a short time, almost half the time of the cycle used with respect to other balancers in this range.

2.1 TECHNICAL SPECIFICATIONS

The following data refers to the balancer in its standard configuration.

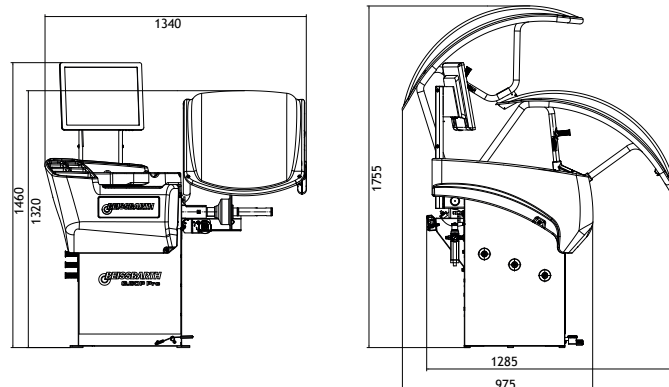

Single-phase power supply	115 / 230 V 50/60 Hz
Protection class	IP 54
Rated power	0,15 kW
Balancing speed	100 min ⁻¹
Cycle time for wheel	4.7 s (5 3/4"x14") 15 kg
Measurement uncertainty	0,5 g
Average noise	< 70 dB (A)
Rim width setting range	1.5" ÷ 20" or 40 ÷ 510 mm
Diameter setting range	10" ÷ 30" or 265 ÷ 765 mm
Min/max. compressed air pressure	7 ÷ 10 kg/cm ²
	approx. 0.7 to 1 MPa
	approx. 7 to 10 bar
	approx. 105 to 145 psi
Maximum wheel weight	< 75 kg
Machine weight	120 kg

2.2 DIMENSIONS

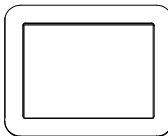
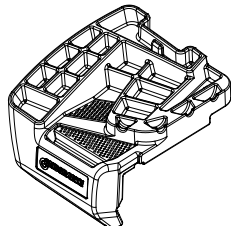
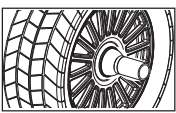

2.3 COMPONENTS

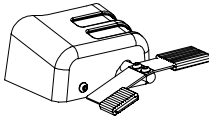
			
TOUCH CONTROL PANEL			✓
WEIGHT-TOOL HOLDER			✓
COLLAR			✓

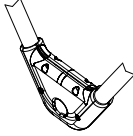
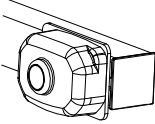
BP PEDAL		✓
INTERNAL SCANNING LASER		✓
LA SONAR		✓
EMS SONAR		✓

2.4 CLEANING INTERNAL LASERSCAN

To ensure correct operation, it is advisable to clean the internal LaserScan sensor any time that you want to calibrate the internal LaserScan.



**DO NOT USE SPRAY PRODUCTS OR COMPRESSED AIR DIRECTLY ON THE SENSOR.
CLEAN THE SENSOR WITH THE KIT PROVIDED OR WITH COMPATIBLE PRODUCTS.
YOU MAY ALSO USE A CLEAN COTTON CLOTH AND DISTILLED WATER.
DO NOT POUR LIQUIDS DIRECTLY ON THE SENSOR, BUT HELP YOURSELF WITH A CLOTH.
DO NOT USE SOLVENTS, KETONES, ALCOHOL OR DEGREASERS.**

PROCEDURE:

1. Turn the body of the LaserScan triangulation sensor manually until it is in a correct working position.
2. Use the kit provided with the product, including the wipes, to clean the entire front surface where the lens and laser diode are positioned.
3. Manually reposition the body of the LaserScan triangulation sensor in the rest position.

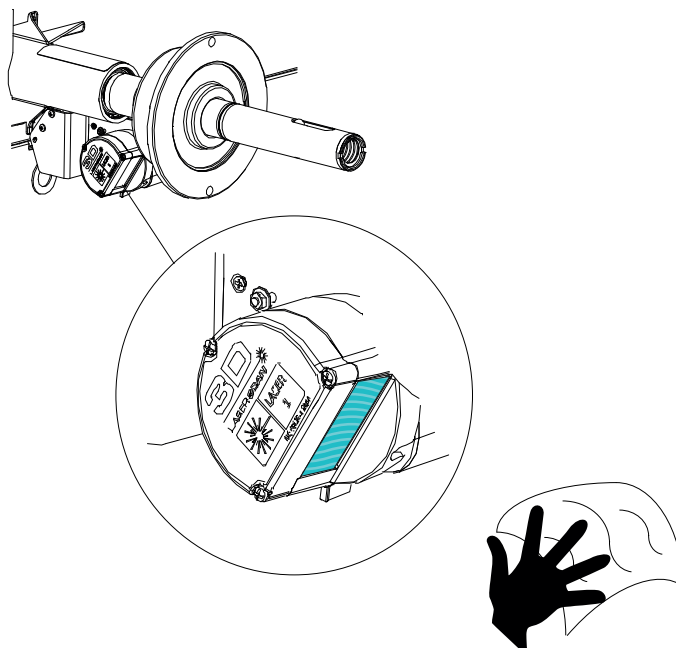

3. Starting



BEFORE SWITCHING ON THE MACHINE, MAKE SURE THAT ALL THE CONNECTIONS DESCRIBED IN THE INSTALLATION CHAPTER HAVE BEEN MADE CORRECTLY.

THE FOLLOWING OPERATIONS INVOLVE A POTENTIAL RISK FOR THE OPERATOR, GIVEN THE PRESENCE OF VOLTAGE ON THE EQUIPMENT. THE PERSONAL PROTECTIVE EQUIPMENT DESCRIBED IN THE INSTALLATION MANUAL MUST BE WORN AND WORK MUST BE DONE WITH DUE CARE AND ATTENTION. OPERATIONS MAY ONLY BE PERFORMED BY A SPECIALISED TECHNICIAN.

Before powering the machine, carry out the following checks:

1. Check that the balancing machine touches the floor at the three support points.

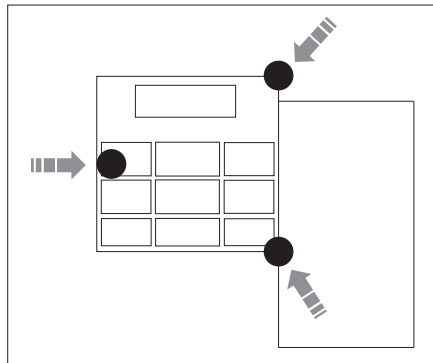

2. Make sure that all the parts of the balancer are correctly connected and fixed.
3. Make sure that the parameters (voltage and frequency) of the mains power supply are compatible with those indicated on the rating plate of the balancer.
4. Make sure the power cable is correctly connected.
5. Make sure the machine shaft and flange hole are clean.



ANY TRACES OF DIRT MAY AFFECT BALANCING ACCURACY.

6. To turn on the wheel balancer press the switch on the side or back of the same; for the models with touchscreen don't touch the screen.

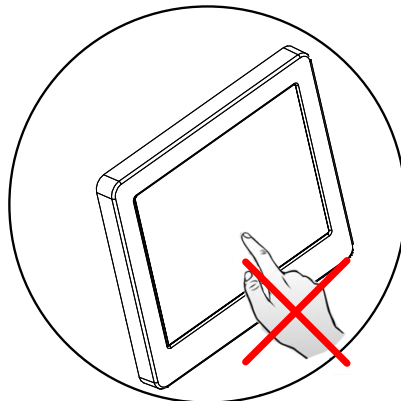

PRESS THE BUTTONS WITH YOUR FINGERS. NEVER USE THE COUNTERWEIGHT GRIPPERS OR OTHER POINTED OBJECTS!

7. Position the wheel on the terminal with the inner part facing the balancer.

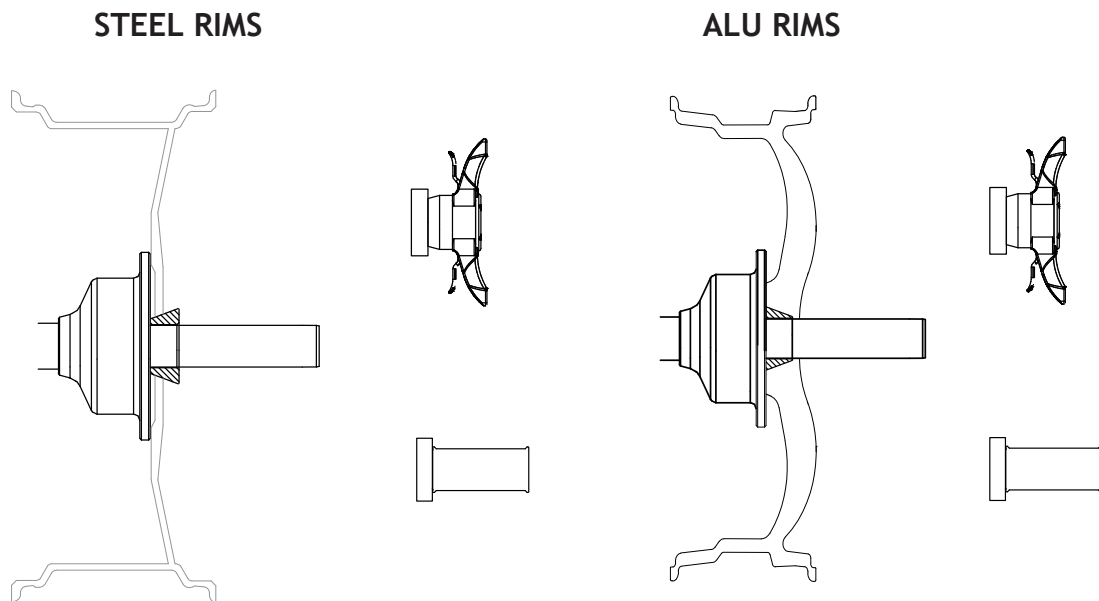

8. Firmly attach the wheel to the balancer shaft using the lock nut. In the pneumatic version, use the specific collar provided. For operation of the spindle with pneumatic locking (constant thrust air spring) connect the wheel balancer to the compressed air mains. The connection fitting is located at the back of the machine. At least 7 kg/cm^2 (~ 0.7 MPa; ~7 bar; ~105 psi) pressure is needed for correct operation of the release device.
9. In the pneumatic version, the pedal allows fastening/releasing the wheel on the adapter using the collar.
10. At this point, you can read the tyre measurements and perform balancing.
11. To perform the spin, lower the splash guard, when fitted and, if necessary and available, press the START button.
12. The wheel is automatically locked when reaching the correct angular position for weight application on the inside and outside, turning it slowly by hand. To unlock the wheel, turn it hard to move it from the correct correction position. If the unbalance is within tolerance, the wheel is locked automatically.



IT IS PROHIBITED TO TOUCH ANY PART OF THE MACHINE DURING THE BALANCING CYCLE.

4. Correction plane identification

ENGLISH

- Standard dynamic balancing using only clip-on weights:

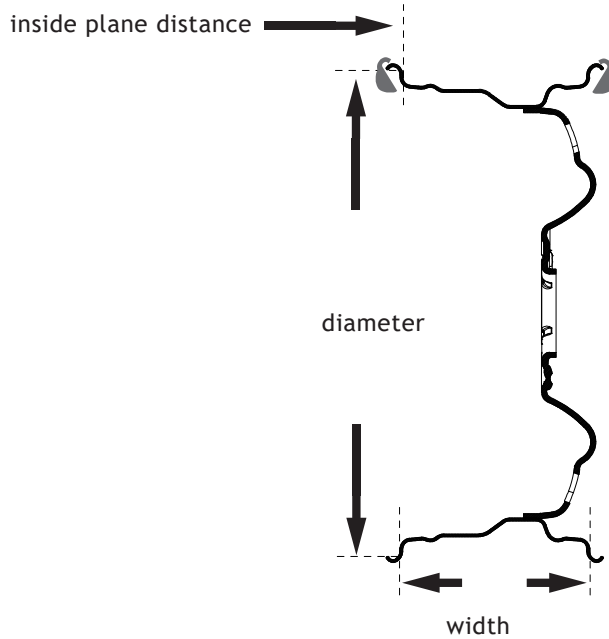

- Standard dynamic balancing using adhesive weights or a mix of adhesive and clip-on weights:

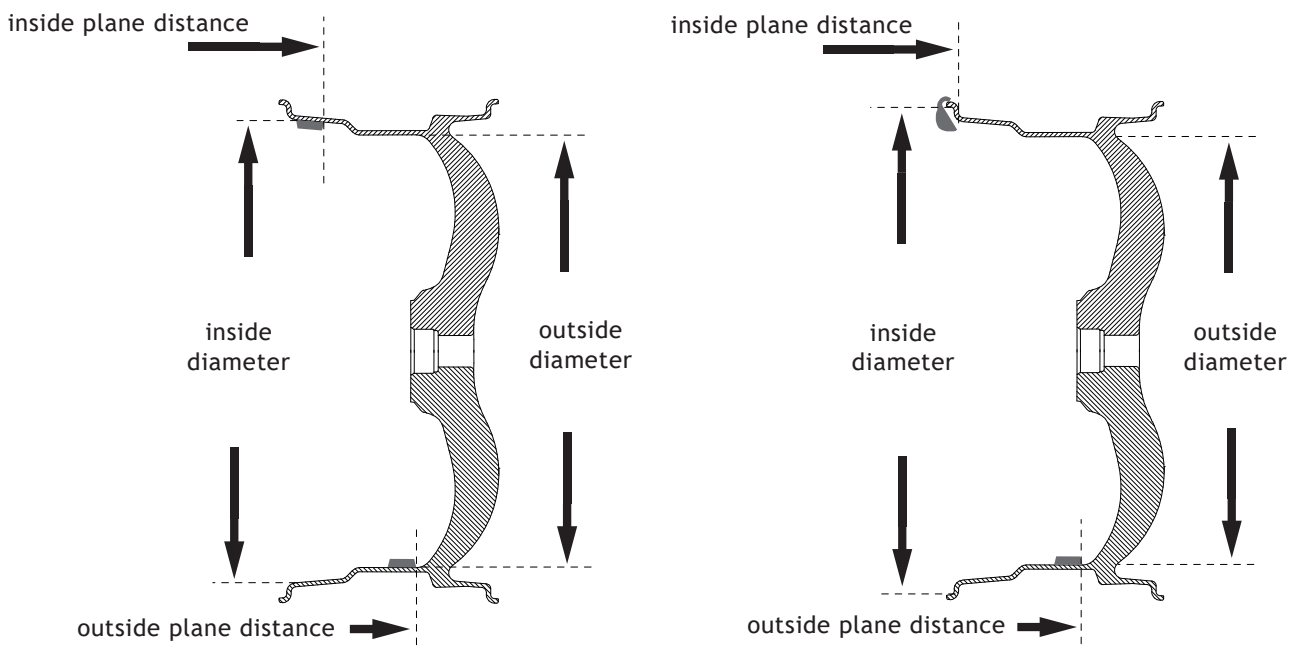

5. Use of the wheel balancer

5.1 INITIAL SCREEN

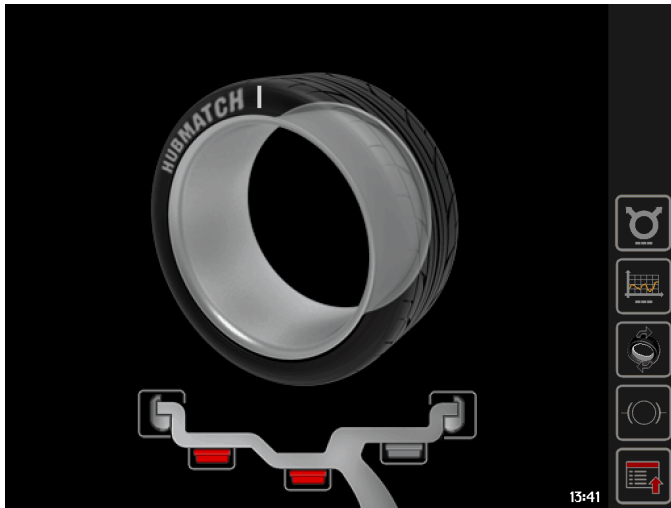

unbalance split

[---] indicates active function but not available in the current configuration



selects the eccentricity screen

[---] indicates active function but not available in the current configuration



automatic wheel positioning



wheel locks/unlocks



main functions screen

( MENU ACCESS DIAGRAM)

If the machine remains on the initial screen for a certain amount of time without being used, the system is automatically switched to a screen-save. Striking of any key, movement of the wheel of distance + diameter gauge will cause automatic switching from the screen-save menu to the initial screen.



WHEN THE SCREENSAVER IS ACTIVE, AUTOMATIC STARTING ACTIVATED BY THE GUARD IS NOT AVAILABLE FOR SAFETY REASONS.

5.2 WHEEL DIMENSIONS SETTING

The automatic acquisition of dimensions is enabled every time the spindle is closed.



FUNCTION ON INDICATOR: Sonar "WIDTH"





In case of disabled automatic LT ( **SETUP - OPTIONS**)

Improves the dimensional calibration of large-diameter wheels such as off-road, trucks, wheels which protrude significantly from the rim. Press it several times to select the type of tyre projection (from 1.0" to 2.0"). The option is disengaged at the end of current width measurement.

Slowly lower the guard to automatically measure the wheel width with LA sonar and perform a measurement spin.

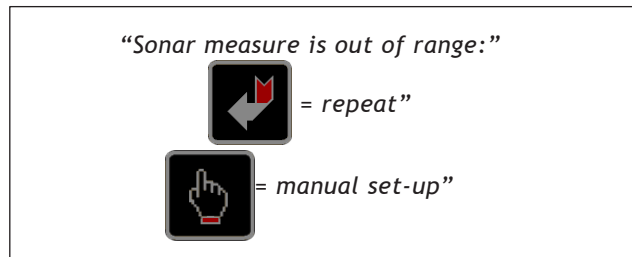
If the width measured is incorrect (out of range), the following message appears:



Press  to re-lower the guard and repeat the width measurement.

Press  to go to the dimensions panel where you can manually enter the width measurement.

In case of incorrect automatic dimension reading or to change the automatically proposed dimensions  **SETTING DIMENSIONS OF THE CORRECTION PLANES.**

5.2.1 Result of the measurement and clip-on weight application

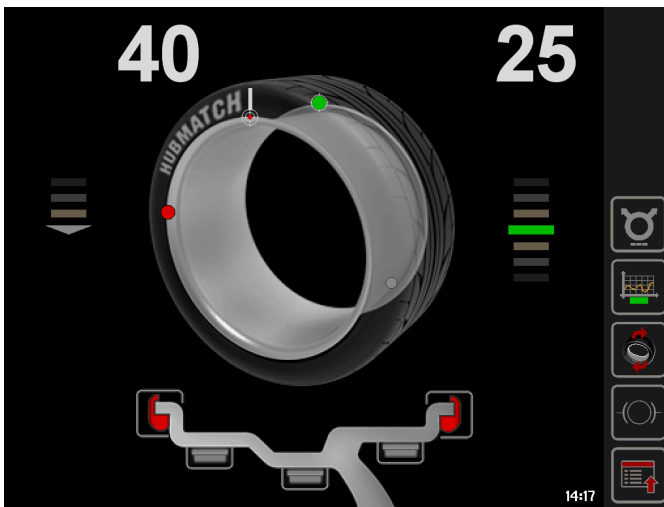



40
25

Inside unbalance indicator

Outside unbalance indicator

If the unbalance is out of tolerance:

- At the end of the spin, the wheel automatically positions on the outer side (on the inner side if the outer side is already within tolerance). In case of both sides (or static) within tolerance, no positioning is carried out. The spindle is automatically locked in correction position (if not disabled the spindle lock and for rotation speeds less than 20 rpm).
If the acoustic signal is enabled (👉 **MENU - ACOUSTIC SIGNAL**), a beep will sound when the correction position has been reached.
- If the **ONE PLANE BALANCING**  / **ONE PLANE BALANCING**  buttons are displayed (👉 **OPB**)
- The symbol  is shown on the display on the side corresponding to the active correction plane
- Manually apply the number of weights shown on the display on the rim at 12 o'clock using clip-on weights:



IF THE OUT-OF-BALANCE IS LESS THAN THE CHOSEN THRESHOLD VALUE, "OK" APPEARS INSTEAD OF THE OUT-OF-BALANCE VALUE TO INDICATE, ON THAT PARTICULAR SIDE, THAT THE WHEEL IS IN TOLERANCE; IF AUTOADAPTIVE CORRECTION METHOD IS DISABLED (👉 **BALANCING SETUP**), PRESS ON THE UNBALANCE INDICATORS TO DISPLAY THE RESIDUAL VALUE BELOW THE CHOSEN THRESHOLD.



- Press  to position the wheel on the other side and correct the unbalance according to what is shown on the screen
- After applying the weights, spin the wheel to check the correction made checking that both planes are within tolerance.

If [HUBMATCH] appears (👉 **RUNOUT SETUP (OPTION) - HubMatch™**).

Enabled buttons:



unbalance split, not available in the current configuration



enables the eccentricity measurement graph

1. The symbol above the key is displayed in yellow if the first harmonic eccentricity exceeds the limit set in the setup parameters (👉 **RUNOUT SETUP - FIRST HARMONIC LIMIT**)
2. When this push button is held down for more than 1.5 seconds, eccentricity measurement is temporarily disabled (enabled in **SETUP**). To re-enable eccentricity measurement, press the same button again for more than 1.5 seconds.

Every time the machine is switched on, the status of eccentricity measurement reflects the settings in **SETUP**



selects the correction mode. When the mode is changed, the unbalance values are recalculated automatically on the basis of the previous spin. Simultaneous display of the dynamic+static unbalance can be enabled through the special function in Setup (👉 **STATIC ALWAYS ENABLED**)



automatic wheel positioning



wheel locks/unlocks



selects the special functions.

5.2.2 Result of the measurement and adhesive weight application (alu)

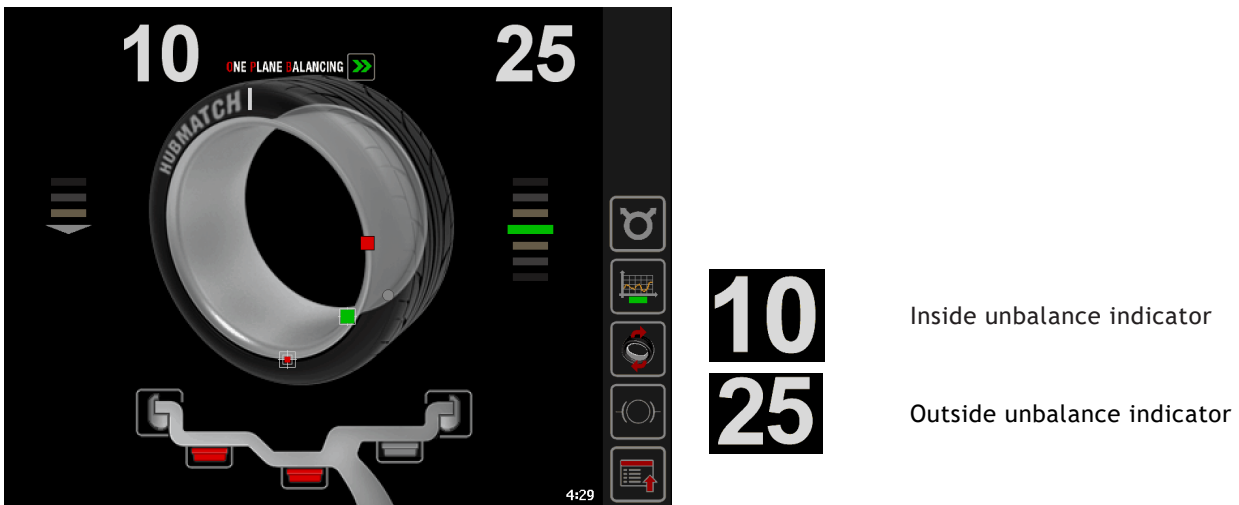

10
25

Inside unbalance indicator

Outside unbalance indicator

If the unbalance is out of tolerance:

- At the end of the spin, the wheel automatically positions on the outer side (on the inner side if the outer side is already within tolerance). In case of both sides (or static) within tolerance, no positioning is carried out. The spindle is automatically locked in correction position (if not disabled the spindle lock and for rotation speeds less than 20 rpm).

If the acoustic signal is enabled (👉 **MENU - ACOUSTIC SIGNAL**), a beep will sound when the correction position has been reached.

- If the **ONE PLANE BALANCING**  / **ONE PLANE BALANCING**  buttons are displayed (👉 **OPB**)

- The symbol  is shown on the display on the side corresponding to the active correction plane.

- The laser projects an indication inside the rim.

- Apply the number of weights shown on the display on the side corresponding to the active plane. The weight is to be applied according to the following convention:



THE ADHESIVE WEIGHTS MUST ALWAYS BE APPLIED STARTING FROM THE LASER INDICATION TOWARDS THE INSIDE OF THE RIM.



IF THE OUT-OF-BALANCE IS LESS THAN THE CHOSEN THRESHOLD VALUE, "OK" APPEARS INSTEAD OF THE OUT-OF-BALANCE VALUE TO INDICATE, ON THAT PARTICULAR SIDE, THAT THE WHEEL IS IN TOLERANCE; IF AUTOADAPTIVE CORRECTION METHOD IS DISABLED (👉 **BALANCING SETUP**), PRESS ON THE UNBALANCE INDICATORS TO DISPLAY THE RESIDUAL VALUE BELOW THE CHOSEN THRESHOLD.

- Press  to position the wheel on the other side and correct the unbalance according to what is shown on the screen

7. After applying the weights, spin the wheel to check the correction made checking that both planes are within tolerance.

If [HUBMATCH] appears (👉 *RUNOUT SETUP (OPTION) - HubMatch™*).

Enabled buttons:



enables the unbalance SPLIT function (not active in case of OPB correction)



enables the eccentricity measurement graph

1. The symbol above the key is displayed in yellow if the first harmonic eccentricity exceeds the limit set in the setup parameters (👉 *RUNOUT SETUP - FIRST HARMONIC LIMIT*)
2. When this push button is held down for more than 1.5 seconds, eccentricity measurement is temporarily disabled (enabled in *SETUP*). To re-enable eccentricity measurement, press the same button again for more than 1.5 seconds.

Every time the machine is switched on, the status of eccentricity measurement reflects the settings in *SETUP*



selects the correction mode. When the mode is changed, the unbalance values are recalculated automatically on the basis of the previous spin. Simultaneous display of the dynamic+static unbalance can be enabled through the special function in Setup (👉 *STATIC ALWAYS ENABLED*)



automatic wheel positioning



wheel locks/unlocks





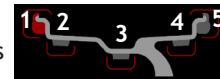

selects the special functions.

5.3 BALANCING WITH A MIX OF ADHESIVE AND CLIP-ON WEIGHTS (STATIC BALANCING)

After dimension acquisition in standard balancing mode, pressing the buttons



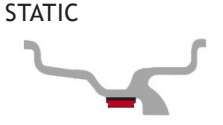

you can select one of the following correction modes.

 WEIGHT APPLICATION POSITION		
Correction type	Inside	Outside
	Clip-on weight at 12 o'clock	Clip-on weight at 12 o'clock
	Clip-on weight at 12 o'clock	Adhesive weight at 12 o'clock
	Adhesive weight at the point indicated by the internal laser	Clip-on weight at 12 o'clock
	Adhesive weight at the point indicated by the internal laser	Adhesive weight at 12 o'clock

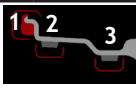
	<p>Adhesive weight at the point indicated by the internal laser</p>
---	---

After dimension acquisition in ALU mode, pressing the buttons  you can select one of the following correction modes. The adhesive weight application distance and diameter are measured by means of the automatic distance and diameter gauge, except for the static unbalance where the dimensions acquired are modified following some fixed parameters.

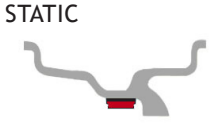
 WEIGHT APPLICATION POSITION		
Correction type	Inside	Outside
	<p>Adhesive weight at the point indicated by the internal laser</p>	<p>Adhesive weight at the point indicated by the internal laser</p>
	<p>Clip-on weight at 12 o'clock</p>	<p>Adhesive weight at the point indicated by the internal laser</p>
	<p>Adhesive weight at the point indicated by the internal laser</p>	



IF THE LASER IS DISABLED, THE WEIGHT APPLICATION POSITIONS REMAIN AS INDICATED IN THE TABLE.

5.4 STATIC UNBALANCE



To display the static unbalance press the “correction mode” button, then press near the static weight

The correction weight application diameter cannot be set, but is deduced from the dimensions acquired in standard or ALU mode through interpolation algorithms and the use of fixed parameters.

The axial application distance of the adhesive weight inside the rim is calculated so as to reduce the residual unbalance to a minimum and is indicated by the laser device.

Tolerance, wheel positioning, brake and laser control is the same as for standard balancing, only that it refers to a single correction plane.

5.5 OPB (ONE PLANE BALANCING)

One Plane Balancing allows correcting the wheel unbalance by applying a single correction weight that cancels out the static unbalance and also reduces the remaining unbalance in the outside planes to a minimum and within tolerance. When the spin is complete, if OPB is possible, the machine automatically ( **BALANCING SETUP**) suggests applying a single correction weight:

- **ADHESIVE WEIGHT:** apply the required weight in correspondence to the internal laser indication.
- **CLIP-ON WEIGHT:** apply the required weight on the side indicated by the wheel balancer in correspondence to the laser indication at 12 o'clock.

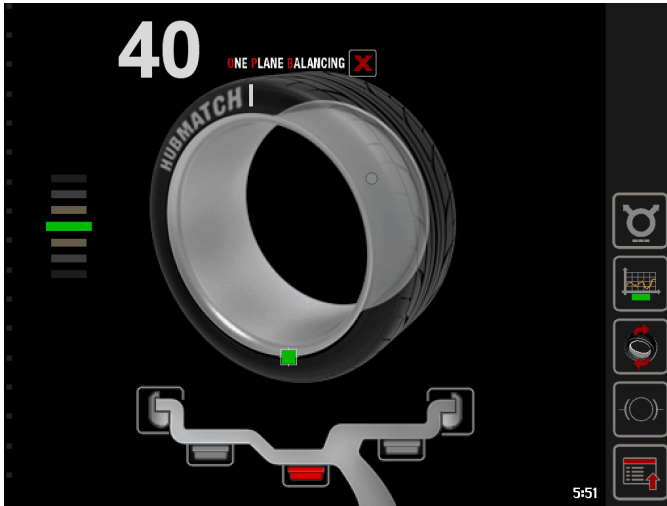

- To go back to plane correction, press the  button

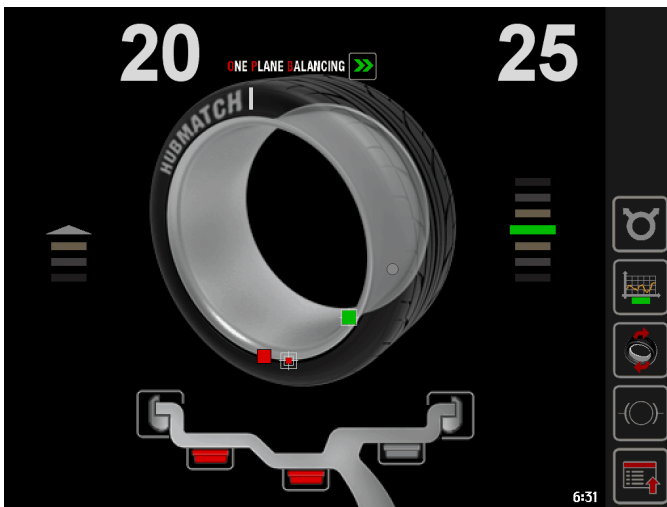

- Pressing the  /  buttons, you can at any time switch between OPB correction and plane correction.





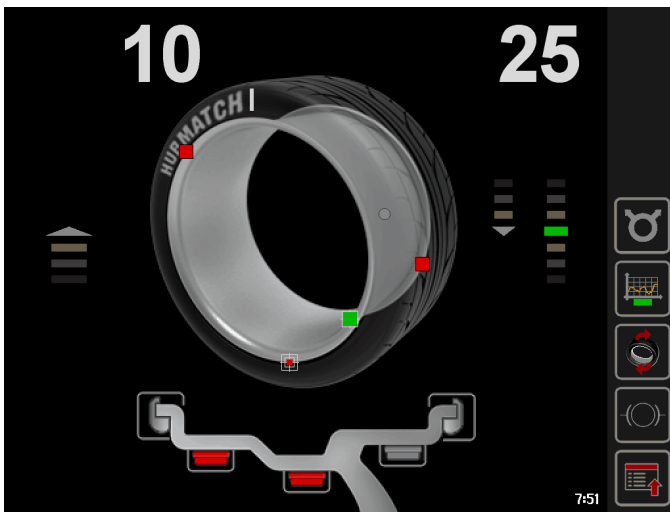

IF ONE PLANE BALANCING CORRECTION METHOD IS ENABLED, IT ISN'T POSSIBLE THE UNBALANCE SPLIT.

5.6 HIDE THE ADHESIVE WEIGHTS (SPLIT)

SPLIT is only possible in the event of static unbalance or ALU external side and is used to hide any adhesive weights correcting unbalance behind the rim spokes.



1. Position the static unbalance or outside ALU in the in the correction position: .
2. Bring the first spoke aligned with the laser and press the  button.
3. Turn the wheel in the unbalance rotation direction indicated on the screen until the second spoke is in the position indicated by the laser and press the  button.
4. Two indications appear on the screen for positioning of the outside correction plane.
5. Press  to turn automatically the wheel to the correction positions and correct the value displayed.

5.7 AUTOMATIC MINIMIZATION OF STATIC UNBALANCE

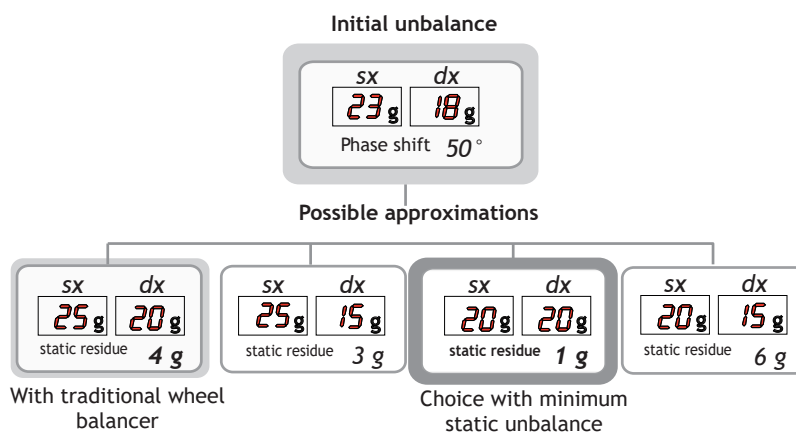

This program is designed to improve the quality of balancing without any mental effort or loss of time by the operator. In fact by using the normal commercially available weights, with pitch of 5 in every 5 g, and by applying the two counterweights which a conventional wheel balancer rounds to the nearest value, there could be a residual static unbalance of up to 4 g. The damage of such approximation is emphasized by the fact that static unbalance is cause of most of disturbances on the vehicle. This new function, resident in the machine, automatically indicates the optimum entity of the weights to be applied by approximating them in an “intelligent” way according to their position in order to minimize residual static unbalance.

5.8 UNBALANCE OPTIMIZATION

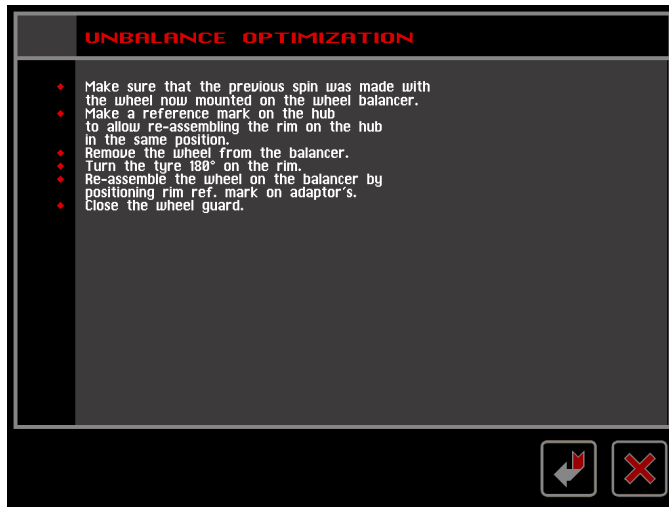

returns to the initial screen





returns to the measurement screen

The program allows total wheel out-of-balance to be reduced by compensating, when possible, tyre and rim out-of-balance values. It requires two runs, rotating the tyre on the rim on the second run.

Having performed a run, press  +   and follow the on-screen instructions.

5.9 SETTING DIMENSIONS OF THE CORRECTION PLANES

Press  +   from the unbalance measurement screen.

To be used only in case of malfunction of the automatic dimension setting due to rims with particular dimensions/ reflecting colours or in the event that it is necessary to modify the correction positions indicated by the laser that the machine detects automatically.



allows entering the manual wheel size setting screen, displaying the dimensions acquired automatically by the balancer and enabling manual modifications, if necessary.

Follow the simple indications shown on the screen pointing the laser in the position where to apply the correction weights:

- internal clip-on weight: point the laser in the same position where the clip-on weight will be applied inside the rim edge
- adhesive weight: point the laser at the beginning of the adhesive weight, in the same position where the system will ask to apply the correction weight.

To set the diameter, rotate the wheel.

Press .

Rotate the wheel until the laser points at the position where the correction weights should be applied and press



5.10 WHEEL ECCENTRICITY MEASUREMENT AND OPTIMISATION

5.10.1 Wheel eccentricity measurement

The EMS sonar (Eccentricity Measurement System) correctly positioned in the centre of the tread and the inner scanning laser automatically measure the wheel eccentricity (👉 *ECCENTRICITY AND MATCHING: THEORY*) during the unbalance measurement spin.

When the first harmonic tolerance limit is exceeded (👉 *RUNOUT SETUP - FIRST HARMONIC LIMIT*), the  button is shown on the display with a red band.

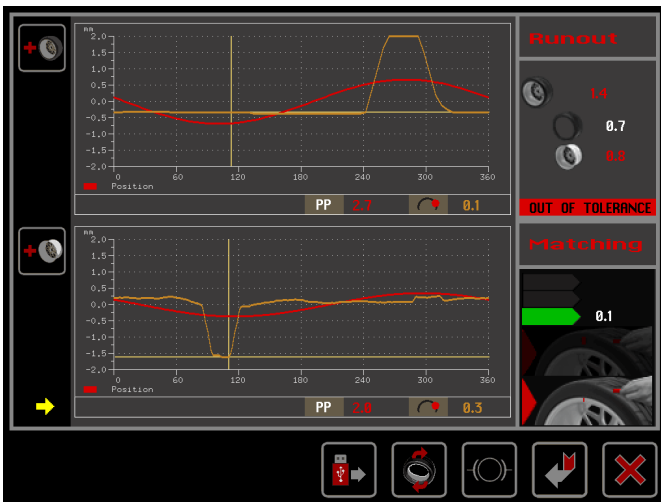

GRAPH 1 (yellow): shows the real peak-to-peak eccentricity.
 GRAPH 2 (red): shows the first harmonic eccentricity.

When the wheel is moved the cursor on the graph indicates the current value with the phase referred at 12 o'clock. are aligned.

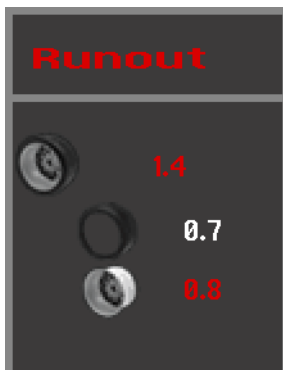

- Wheel runout (rim plus tyre):
- Tyre runout
- Rim runout

The wheel and rim runout values are shown in white if they are within tolerance and in red if they are out of tolerance.

IN TOLERANCE displayed when the wheel runout is within tolerance.

OUT OF TOLERANCE displayed when the wheel runout is out of tolerance.

In case of disabled wheel or rim runout (👉 *OPTIONS - RUNOUT SETUP*), a single graph is displayed, and the Matching function is not available. In case of disabled wheel and rim runout, access to the eccentricity screen (runout) is disabled.

5.10.2 Matching

The purpose of Matching is to reduce the overall runout of the wheel by rotating only the tire on the rim in such a way as to minimize the wheel runout and, if possible, bring it within tolerance. The balancer provides clear indications of the Matching result:

No indication

Matching is not required: the wheel is already in tolerance



Matching is not recommended: the wheel will be out of tolerance again

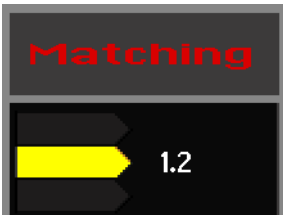

You can do matching but the wheel might be out of tolerance again

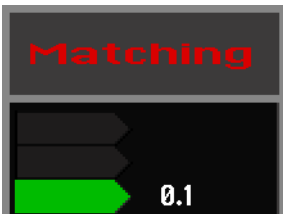

You should do matching: the wheel will be better than tolerance

The numbers displayed next to the arrows indicate the wheel runout value expected at the end of the Matching.

5.10.2.1 How to perform matching

- Move the wheel into the positions where to mark the tyre and the rim by turning the wheel by hand or by pressing the on-screen button



Tyre



Rim

- The h12 laser, if enabled, indicates where mark with a chalk the tyre or the rim
- Turn the tyre on the rim until the two marks coincide.

To check the matching result, return to the measurement screen, mount the wheel and perform a spin.

5.11 ECCENTRICITY AND MATCHING: THEORY

The software associated with eccentricity measurement is a powerful tool for determining the need to perform relative rotation between the rim and tyre in order to reduce the eccentricity of the wheel down to acceptable limits. The principle adopted is based on the consideration that a rim with acceptable tolerance, mounted with an acceptable tyre, can statistically generate a total eccentricity which is not acceptable but can be improved by matching.

Generally speaking, rim measurement is not necessary, accurate or useful because:

- To measure the rim it is necessary to remove the tyre. There can be coarse errors on the outside (e.g. aluminium wheels!)
- The two rim sides can be eccentric in a very different way. Therefore to which one to make reference? What is the effect on the tyre mounted?
- To improve the eccentricity of a wheel, **the rim should be eccentric**, to compensate the tyre. And viceversa.
- If after a rotation by 180° of a wheel, the value is still out-of-tolerance, either the tyre or rim are too eccentric: One of the two must be replaced!

Example 1

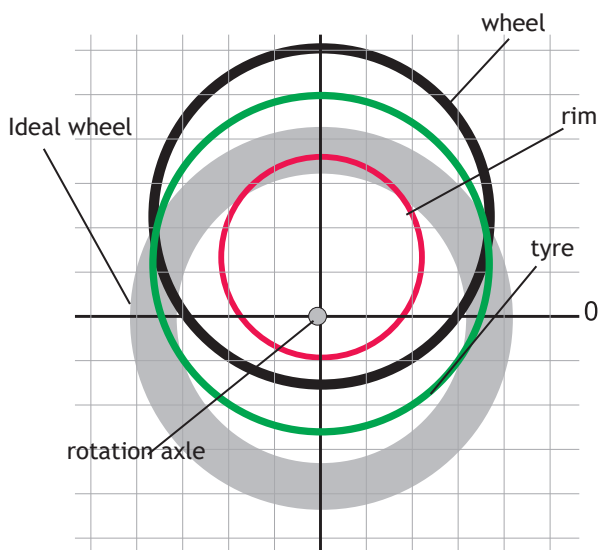

Rim + 0.8 mm
Tyre + 0.6 mm

Wheel + 1.3 mm

Eccentricity of the wheel is excessive, due to an acceptable rim or tyre but randomly placed in an "unfortunate" relative position.

SOLUTION: Rotate the tyre on the rim by 180°

RESULT: wheel eccentricity 0.3 - 0.4 mm
(in tolerance)

Example 2

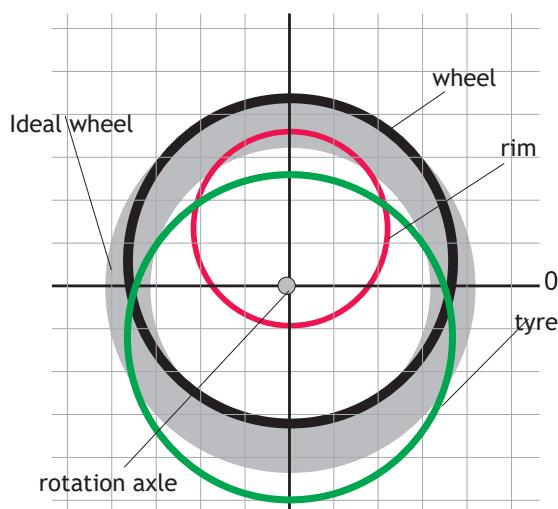

Rim + 0.8 mm
Tyre - 0.6 mm

Wheel + 0.3 mm

Eccentricity of the single items has been compensated.

The wheel is acceptable.

Example 3

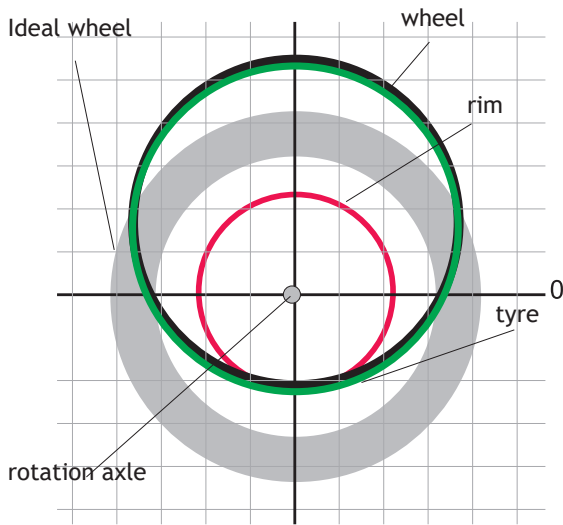

Rim 0 mm
Tyre + 1.2 mm

Wheel + 1,2 mm

Eccentricity of the wheel cannot be compensated by the rotation because the rim is perfect!

SOLUTION: rotate the tyre on the rim by 180°
RESULT: no improvement is obtained.

5.11.1 Presetting of tolerance on the machine

There is no general rule concerning acceptability of an eccentricity value. As a first approximation we consider it correct to use a threshold of 1 to 1.5 mm. The E/ECE/324 standard prescribes 1.5 mm as max. eccentricity of a rebuilt tyre.

5.11.2 Value of static unbalance, correlated with eccentricity

Clear indication is given in the Measurement screen of both the value and position of the static unbalance as well as the eccentricity. In fact, it is interesting to check the correlations of the two values, above all of the two positions. When the two positions have a similar angle ($\pm 30^\circ$ one from the other), there is a **clear sign that an eccentricity is present which can be compensated by matching.**

5.11.3 Value of unbalance corresponding to eccentricity

For user's reference, the centrifugal force is calculated corresponding to a certain speed, compared to the force generated by the eccentricity present on the tyre (calculated with an approximate average elastic constant).

6. Menu

6.1 MENU ACCESS DIAGRAM

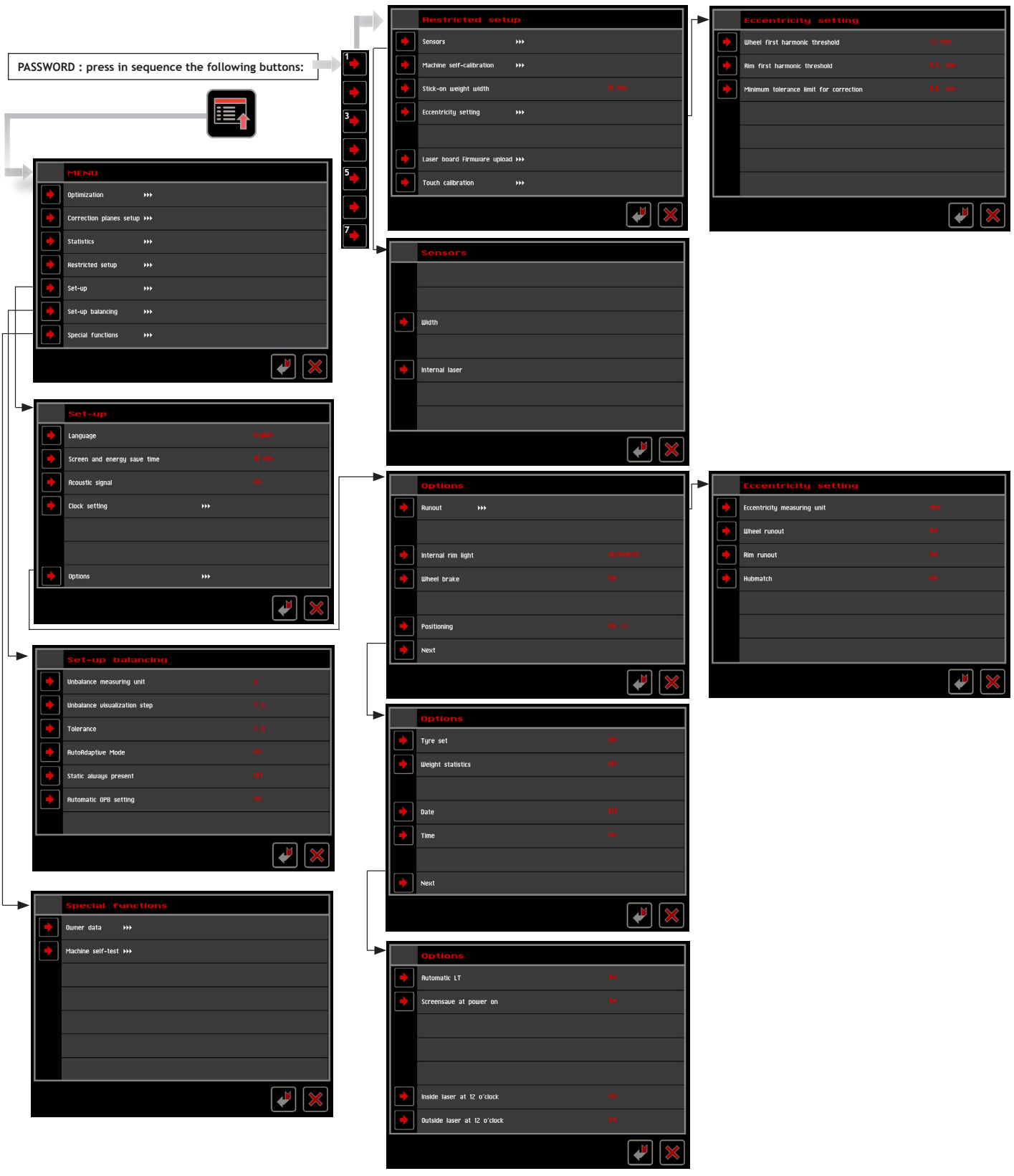

6.2 STATISTICS



- 1 / 2 resets the relative counter
For the TOTAL counters a correct password must be entered.
- 3 accesses to the weight statistics screen
- returns to the previous screen
- returns to the measurement screen

DAILY N° OF RUNS:

Indicates the number of runs performed as from switching on the machine. Such parameter is automatically reset after switching the machine off.

TOTAL N° OF RUNS:

Indicates the number of runs starting from the date indicated in square brackets. This parameter remains memorized even when the machine is switched off.

6.2.1 Weight statistics screen

g	[]	[]
5	6	0
10	3	0
15	5	1
20	18	2
25	24	11
30	31	15
35	27	10
40	18	6
45	9	3
50	11	3
55	5	0
60	5	0
TOT g	5220	1655
TOT n	162	51

- resets the weight statistics screen by pressing and entering the password
- returns to the previous screen
- returns to the measurement screen

Each horizontal line indicates the number of clip-on and adhesive weights used to balance the wheels in the period between the two dates indicated on the screen (in square brackets).

- **Tot g (Tot oz):** indicates the total weight value (clip-on and adhesive weights) used to balance the wheels in the interval indicated on the screen
- **Tot n:** indicates the total number of clip-on and adhesive weights used to balance the wheels in the interval indicated on the screen.



TO ENABLE SAVING OF THE WEIGHT STATISTICS
(WEIGHT STATISTICS SCREEN).

THE WEIGHTS ARE SAVED ONLY IF THE UNBALANCE DISPLAY PITCH IS SET TO 5 IN 5.

6.3 CALIBRATIONS

When   is pressed from the Special Functions menu, access is gained to the Calibration menu.

6.3.1 Sensors calibration

6.3.1.1 Width sonar calibration

Fit the calibration tool as shown in the figure and press the confirmation button :

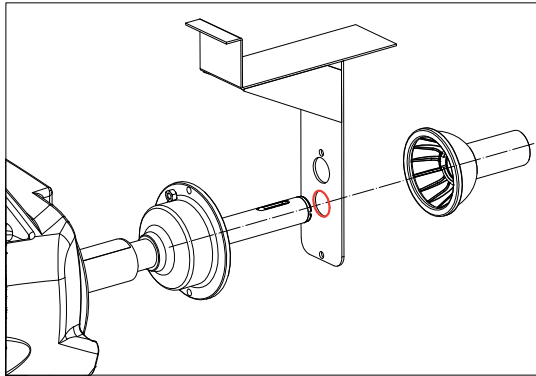

Follow the simple on-screen instructions.

Enabled buttons:



confirms



cancels the width sonar calibration function if has erroneously been accessed.

6.3.1.2 Internal laser calibration



**BEFORE THE CALIBRATION OF THE INTERNAL LASER,
PERFORM THE CLEANING AS INDICATED IN THE PARAGRAPH  CLEANING INTERNAL LASERSCAN**

1. Open the spindle and fit the specific calibration tool as shown in the figure:

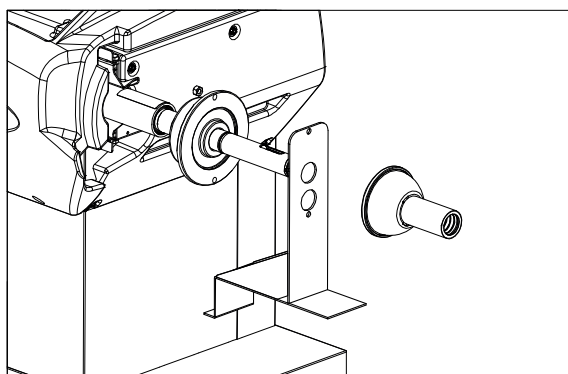

Follow the simple on-screen instructions, paying attention to the correct assembly of the tool in the two required positions.

Enabled buttons:



confirms



cancels the internal laser calibration function if has erroneously been accessed.

6.3.2 Balancing machine calibration

To calibrate the balancing machine, use a wheel with steel rim of average dimensions, e.g. 6" x 15" (± 1 ").

To properly perform the procedure:

- Mount a wheel on the machine, even unbalanced, and very carefully set its dimensions.



SETTING INCORRECT MEASUREMENTS WILL RESULT IN THE MACHINE NOT BEING CORRECTLY CALIBRATED, AND BALANCING OF SUBSEQUENT WHEELS WILL HENCE BE INCORRECT UNTIL THE MACHINE IS RECALIBRATED WITH THE CORRECT MEASUREMENTS!!

- Follow the on-screen instructions.

6.3.3 Adhesive weight width

Indicates the average width of the adhesive weights on the market.

Change ONLY if the width of the adhesive weights used for unbalance correction differ +/- 3 mm with respect to that shown on the screen (default=19mm).

6.3.4 Runout Setup

Enables display of a menu where the following parameters can be set:

Wheel first harmonic threshold	represents the first harmonic limit beyond which it is considered appropriate to turn the tyre on the rim by 180°. Recommended limit = 1.2 mm.
Rim first harmonic threshold	represents the first harmonic limit of the rim below which it is not considered appropriate to turn the tyre on the rim. Recommended limit = 0.3 mm.
Minimum tolerance limit for correction	represents the minimum correction limit obtainable below which it is not considered appropriate to turn the tyre on the rim. Recommended limit = 0.8 mm.

6.3.5 Loading laser board firmware



PROCEDURE TO BE PERFORMED ONLY BY SPECIALIZED PERSONNEL.

Contact the support service to handle the update and follow the simple on-screen instructions.

6.3.6 Touch screen calibration

Sequentially tap the three points indicated on the touch screen. Calibrate ONLY if the on-screen buttons malfunction.

7. Setup

The Setup screen provides the user with many possibilities required for presetting the machine according to his own requirements. Such settings remain unaltered even when the machine is switched off.

Enabled buttons:



returns to measurement screen



returns to previous screen



selects the parameter.

7.1 LANGUAGE

This function allows selecting the language to be used for displaying descriptive and diagnostic messages regarding machine operation.

7.2 SCREEN-SAVER TIME

If this function is enabled, the screensaver will automatically be activated when the machine is not used for a certain period of time. This function can be disabled by setting it to 0.

7.3 ACOUSTIC SIGNAL

When “ON” is selected, the sending of an acoustic signal (beep) is enabled in the following cases:

- when any push button is pressed;
- when dimensions are acquired in automatic mode;
- when the correct angular position for weight application is reached in the Measurement screen.





7.4 SETTING THE CLOCK

Used to set date and time correctly. Follow the instructions on the screen.

7.5 OPTIONS

7.5.1 Runout setup

Enables display of a menu where the following parameters can be set:

Runout unit of measure	It is possible to select display of runout measurements in mm or inches.
Wheel runout	Enable/disable wheel runout measurement
Rim runout	Enable/disable rim runout measurement
HubMatch™	<p>After performing a check spin, the HubMatch™ box will give indication on where to mark the tire, at 12 o'clock, in correspondence of the first harmonic (RFV) <i>Results will be shown in 3 different colors:</i></p> <p>Green (): HubMatch™ suggested</p> <p>Yellow (): HubMatch™ and Match Mounting recommended</p> <p>Red (): HubMatch™ and Match Mounting possible but not suggested</p> <p>(to modify RFV default limits  FIRST HARMONIC LIMIT)</p> <p>The change of the word Hubmatch from gray to other color indicates to mark the tire when the first harmonic is in position at 12 o'clock.</p>

7.5.2 Rim interior light

AUTOMATIC: enables/disables the rim interior light to automatically switch on.

MANUAL: enables/disables display of the  button on the measurement screen that allows turning the rim interior light on/off.

7.5.3 Wheel locking enable

Enables/disables wheel locking in the correction position.

7.5.4 Wheel positioning





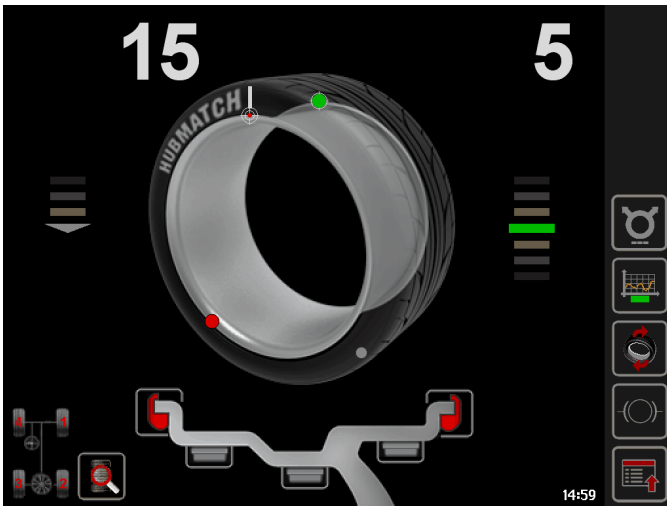

Enables the positioning type:



- ON1: when the measurement spin is complete, the wheel is positioned and held in the correction position.
- ON2: when the measurement spin is complete, the wheel is positioned in proximity of the correction position and released.
- OFF: disables wheel positioning.

7.5.5 Tyre train



This function allows balancing the four wheels of a vehicle, plus the spare wheel if necessary, and obtaining the information on how to fit these wheels on the vehicle in such a way that the vibrations due to residual eccentricity of each wheel is reduced to a minimum. The 'TYRE TRAIN' function can be enabled and disabled from the MENU ( **MENU ACCESS DIAGRAM**). For best use of this function proceed as follows:

1. Gather together adhesive symbols to identify the wheels
2. Press  and  to start the procedure
3. Fit the first wheel and place the radial eccentricity measurement sonar in the correct position  
4. Balance the wheel, identify it using the number 1 and press  
5. Repeat points 3 and 4 for the other three wheels and identify the wheels using the numbers 2, 3 and 4.
6. Each time data is saved, the balancing machine highlights the best fitting solution for the wheels balanced up to that moment.
7. The bottom-left corner of the screen shows a stylised vehicle with four tyres; at each spin the number of the wheel to be fitted in each position (rear/front axle left/right) is indicated on each of the tyres.

The procedure can be rest at any time by pressing  and  .

To obtain an overview of the wheel balancing values, press  .

A window appears:

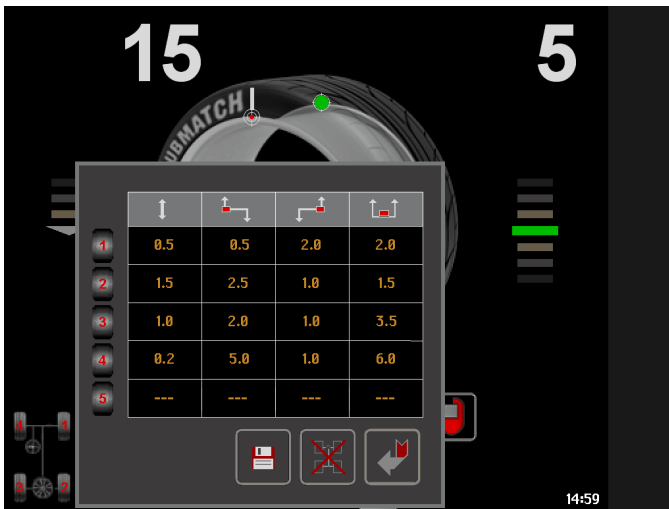

saves the wheel data



resets the tyre set



returns to the measurement screen.

7.5.6 Weight statistics

Enables/disables saving of the weight type used to balance the wheels (**WEIGHT STATISTICS SCREEN**).

7.5.7 Date

Enables/disables date display.

7.5.8 Time

Enables/disables time display.

7.5.9 LT automatic

If set to ON and with EMS enabled, the wheel bulges are automatically calculated; the calculated value can however be modified by pressing the button **WHEEL DIMENSIONS SETTING**).



7.5.10 Power-on screensaver

Enable/disable the display of the screensaver when the machine is powered on.

7.5.11 Inside laser at 12 o'clock

Enables/disables the laser at 12 o'clock indication of the clip-on weight application position for the inside.

7.5.12 Outside laser at 12 o'clock

Enables/disables the laser at 12 o'clock indication of the clip-on weight application position for the outside.

7.6 BALANCING SETUP

7.6.1 Unit of unbalance measurement

It is possible to select whether to display the unbalance values expressed in grams or ounces.

7.6.2 Unbalance display pitch

You can view the unbalances in steps of 5 grams or 1 gram.



FOR FULL USE OF THE WHEEL BALANCER FUNCTIONS, IT IS ADVISABLE TO ALWAYS SET A DISPLAY STEP OF 5 GRAMS (1/4 OZ.).

7.6.3 Tolerance

This is the unbalance threshold below which OK appears on the screen at the end of the spin instead of the numerical value.



7.6.4 AUTOADAPTIVE correction method

The innovative tolerance calculation system AutoAdaptive Mode is based on the evaluation of the residual imbalance limit value corresponding to an acceptable perceived vibration. For each wheel that is balanced, the software AutoAdaptive Mode detects weight and dimensions and calculates the tolerance value that will cancel any vibration perceived on the steering wheel. AutoAdaptive Mode grants the highest comfort when driving, and together with OPB program, saves balancing time.

7.6.5 Static always enabled

Enables/disables the simultaneous display of the selected correction plane and STATIC unbalance.

7.6.6 Automatic OPB selection

Enables/disables automatic display of OPB correction mode at the end of the measurement spin. if the OPB correction mode is available, pressing the  /  buttons, you can at any time switch between OPB correction and plane correction.

7.7 SPECIAL FUNCTIONS

7.7.1 Presetting the customer and user name

The machine can be customised by setting the name that appears on the screensaver.

7.7.2 Wheel balancing machine SELF TEST

An automatic self-diagnostic cycle is provided for easier trouble-shooting.

(Consult the extraordinary maintenance manual or contact Technical Service).

8. Diagnostics

8.1 INCONSISTENT UNBALANCE READINGS

In some cases, when a wheel that has just been balanced is repositioned on the balancer, the machine can detect an unbalance.

This is not a machine problem but is due to faulty mounting of the wheel on the flange. In other words, when mounting the wheel after initial balancing, it has taken another position with respect to the balancer shaft axis.

If the wheel has been mounted on the flange with screws, the screws may not have been tightened correctly (criss-cross sequence) or the tolerances of the holes drilled in the wheel may be too large. Small errors, up to 10 grams (0.4 oz), are to be considered normal in wheels locked with the relative cone: The error is normally greater for wheels locked with screws or studs.

If, after balancing, the wheel is still unbalanced when refitted on the vehicle, this could be due to an unbalanced brake drum or, very often, the tolerances of the holes drilled in the rim and drum are too large. In this case, balancing should be performed using a balancer with the wheel mounted on the vehicle.



THE INFORMATION IN THE POSSIBLE REMEDY COLUMN REQUIRES WORK TO BE PERFORMED BY SPECIALIST TECHNICIANS OR OTHER AUTHORISED PEOPLE WHO MUST ALWAYS WORK USING THE PERSONAL PROTECTIVE EQUIPMENT INDICATED IN THE INSTALLATION MANUAL. IN SOME CASES, THIS WORK CAN BE PERFORMED BY A NORMAL OPERATOR.

ERROR	PROBLEM	POSSIBLE SOLUTIONS
Black	The wheel balancer does not switch on	<ul style="list-style-type: none"> Verify correct connection to the mains Verify and eventually replace the fuses on the power card Verify monitor function Replace the computer board
Err. 1	No rotation signal	<ul style="list-style-type: none"> Check in self-diagnostics that the encoder functions properly Replace the phase pick-up board Replace the computer board
Err. 2	Speed too low during detection During the unbalance measurement revolutions, the wheel speed has fallen to below 42 rpm	<ul style="list-style-type: none"> Make sure that a vehicle wheel is mounted on the wheel balancer Use the self-diagnostics function to check the encoder Disconnect the piezo connectors from the board and do a spin (if no error is detected, replace the piezo sensors) Replace the CPU board
Err. 3	Unbalance too high	<ul style="list-style-type: none"> Verify wheel dimension settings Check detection unit connections Perform machine calibration Mount a wheel with more or less known unbalance (less than 100 grammes) and verify the response of the machine Replace the computer board
Err. 4	Rotation in opposite direction After pressing [START], the wheel starts turning in the opposite direction (anticlockwise)	<ul style="list-style-type: none"> Check in self-diagnostics that the encoder functions properly Check the bearing/spring of the phase generator
Err. 5	Guard open	<ul style="list-style-type: none"> Reset the error Close the guard Verify the function of the protection Switch
Err. 6	Spindle open. Spin enabled without first having closed the spindle	<ul style="list-style-type: none"> Check functioning of the spindle closing microswitch Close the spindle Lower the guard
Err. 7/ Err. 8/ Err. 10	NOVRAM parameter read error	<ul style="list-style-type: none"> Repeat machine calibration Shut down the machine Wait for a minimum time of - 1 min Re-start the machine and verify correct operation Replace the computer board

Err. 9	NOVRAM parameter write error	<ul style="list-style-type: none"> Replace the computer board
Err. 11	Speed too high error During unbalance measurement rotation, wheel speed is more than 270 rpm	<ul style="list-style-type: none"> Check if there is any damage or dirt on the timing disc Check in self-diagnostics that the encoder functions properly Replace the computer board
Err.14 / Err.15 / Err.16 / Err.17 / Err.18 / Err.19	Unbalance measurement error	<ul style="list-style-type: none"> Check in self-diagnostics that the encoder functions properly Check detection unit connections Verify machine earth/ground connection Mount a wheel with more or less known unbalance (less than 100 grammes) and verify the response of the machine Replace the computer board
Err. 22	Maximum number of spins possible for the unbalance measurement has been exceeded	<ul style="list-style-type: none"> Check that a vehicle wheel has been mounted on the wheel balancer Check in self-diagnostics that the encoder functions properly Replace the computer board
Err.24	STOP button pressed during the measurement spin	<ul style="list-style-type: none"> Check the proper functioning of the touch monitor Do not press the STOP button during the measurement spin
Err.25	Calibration wheel's internal profile reading error	<ul style="list-style-type: none"> Repeat the automatic measurement of the dimensions Ensure that you have mounted a medium-sized wheel on the balancer Use a different wheel for the machine's calibration function
Err.26	Outer rim diameter reading error	<ul style="list-style-type: none"> Check in self-diagnostic the correct operation of the EMS sonar Verify that the EMS sonar is correctly positioned in front of the wheel and perpendicular to the wheel itself Verify that a car wheel has been mounted Replace the sonar device Replace the computer board
Err. 30	Clock error	<ul style="list-style-type: none"> Replace the computer board
Err. 35	Error during the firmware update phase for the laser board	<ul style="list-style-type: none"> Verify that you have followed the specifications for using the USB flash drive Verify that you have correctly saved a valid firmware on the USB flash drive Repeat the firmware update procedure for the laser board, making sure to follow the on-screen instructions
Err.40/ Err.41/ Err.42/ Err.43	Eccentricity graph plotting procedure error	<ul style="list-style-type: none"> Perform a new eccentricity measurement
Err.45/ Err.46/ Err.47/ Err.48	Eccentricity graph value display readout error	<ul style="list-style-type: none"> Perform a new eccentricity measurement
Err.50/ Err.51/ Err.52/ Err.53	Eccentricity graph current value cursor plotting procedure error	<ul style="list-style-type: none"> Perform a new eccentricity measurement
Err.54	Sonar readout error Sonar value readout impossible	<ul style="list-style-type: none"> Position the eccentricity measurement sonar correctly before performing the measurement Check eccentricity sonar connections Check the power supplies on the power board Replace the eccentricity measurement sonar Make sure that the wheel does not halt before completing at least 4/5 revolutions after the first braking impulse Replace the computer board
Err.55	Sonar readout error Sonar values are insufficient for correct measurement of eccentricity	<ul style="list-style-type: none"> Position the eccentricity measurement sonar correctly before performing the measurement Make sure that the wheel does not halt before completing at least 4/5 revolutions after the first braking impulse Mount a wheel of medium dimensions (14"x5 3/4") and perform an eccentricity measurement . If in these conditions error 55 no longer occurs, this means that the wheel inertia causing the problem is such as to half the wheel before having acquired the minimum number of values necessary for reliable eccentricity measurement
Err. 60÷67	Internal laser read error during calibration	<ul style="list-style-type: none"> Check that you have correctly fitted the laser calibration tool Check that the laser light spot is able to read the calibration tool Check that there are no objects that may interfere with calibration tool reading Check the correct connection of the cables on the computer board Repeat the laser calibration function
Err. 70÷75	Error in handling the storage of machine configuration parameters	<ul style="list-style-type: none"> Contact the customer support service

Err. 97	Error in number of steps calculated for laser movement	<ul style="list-style-type: none"> Repeat automatic measurement of the distance and diameter Calibrate the laser Calibrate the distance gauge Calibrate the diameter gauge Check mechanical fitting of the laser
Err. 98	Dimensions error	<ul style="list-style-type: none"> Repeat the automatic measurement of the dimensions Calibrate the diameter gauge
Err. 121 Err. 123/124 Err. 125/126 Err. 128/129 Err. 130/134 Err. 135	Internal laser motor control error	<ul style="list-style-type: none"> Reset the wheel balancing machine <p><i>If the problem persists:</i></p> <ul style="list-style-type: none"> Check compatibility between the software and the firmware Reinstall the software and the firmware
Err. 122/131 Err. 142	The internal laser does not reach the position requested	<ul style="list-style-type: none"> Check that there are no mechanical obstructions hindering laser movement Check functioning of the stepper motor belt Check the stepper motor power supply Check the stepper motor connection cables Where provided, check the encoder on the stepper motor slide
Err. 127	Internal laser stepper motor turning in reverse direction	<ul style="list-style-type: none"> Check the stepper motor connection
Err. 132	Internal laser stepper motor movement stopped with STOP command	<ul style="list-style-type: none"> Repeat the measurement avoiding to press the STOP button unless for an emergency
Err. 133	Different internal laser positioning between the stepper motor and the encoder	<ul style="list-style-type: none"> Check functioning of the stepper motor belt Check the encoder on the stepper motor slide
Err. 136	The internal laser does not reach the position requested	<ul style="list-style-type: none"> Check that there are no mechanical obstructions hindering laser movement Check the stepper motor power supply Check the stepper motor connection cables
Err.141/143 Err.144/145	Unbalance measurement error	<ul style="list-style-type: none"> Check the connection of the runout measurement devices Use the self-diagnostics function to check the encoder Verify machine earth/ground connection Replace the acquisition board
Err. 150÷162	Communication error between the PC and the laser acquisition board	<ul style="list-style-type: none"> Turn the wheel balancing machine off and on again Check the Ethernet connection cables between the PC and the laser acquisition board Replace the laser acquisition board
Err. 221÷226	Internal laser read error	<ul style="list-style-type: none"> Check that the light spot is visible on the wheel to be measured Check that you have correctly mounted the wheel to be balanced Check that there are no objects other than the wheel in the laser measuring range Repeat the dimension measurement
Err.230÷238	Operating touch monitor errors	<ul style="list-style-type: none"> Restart the balancing machine Calibrate the touch monitor Check touch monitor connections Replace the touch monitor
Unbalance incorrect with back centring cones	Mount the wheel in vertical position and push the sleeve up against the wheel. If necessary, repeat locking/unlocking/locking and perform the procedure again	<ul style="list-style-type: none"> Mount the wheel in vertical position and push the sleeve up against the wheel. If necessary, repeat locking/unlocking/locking and perform the procedure again.

9. Maintenance

9.1 GENERAL



BEFORE PERFORMING ANY MAINTENANCE OPERATIONS, MAKE SURE THE MACHINE HAS BEEN DISCONNECTED FROM THE MAINS POWER SUPPLY. ALWAYS USE THE PERSONAL PROTECTIVE EQUIPMENT INDICATED IN THE INSTALLATION MANUAL.

9.1.1 Introductory notes

This machine has been designed so as not to require routine maintenance, apart from accurate periodic cleaning. It is important to keep the machine perfectly clean in order to prevent dust or impurities from compromising the operation of the balancer.



THE PEOPLE RESPONSIBLE FOR CLEANING THE AREA WHERE THE MACHINE IS INSTALLED MUST WEAR PERSONAL PROTECTIVE EQUIPMENT IN ORDER TO WORK IN SAFETY AND ACCORDING TO THE CURRENT OCCUPATIONAL HEALTH AND SAFETY REGULATIONS. IN ANY EVENT, THE MAINTENANCE MUST BE CARRIED OUT EXCLUSIVELY BY A SPECIALISED TECHNICIAN TRAINED TO OPERATE ACCORDING TO CEI EN 50110-1 (NFPA70E-2004 SECTION 400.11).

As extraordinary maintenance must be performed by service staff or, in any case, by specifically authorised and trained people, is not dealt with in this manual.

9.1.2 Safety rules

Performing specialist activities on the equipment, particularly if the guards need to be dismantled, exposes people to serious danger due to the presence of potentially live parts.

The rules shown below must be scrupulously followed.

People must always use the Personal Protective Equipment indicated in the Installation Manual. During activities, unauthorised people may not access the equipment and WORK IN PROGRESS signs will be erected in the department in such a way that they are visible from every place of access.

Specialist staff must be authorised and especially trained concerning the dangers that may arise during operation and the correct methods for avoiding them. They must always work with great care and pay full attention.

If, exceptionally, the staff removes the guards to carry out a particular specialist technical maintenance, inspection or repair job, they are required to put them back after work.

After work, staff must make sure that foreign objects, in particular mechanical pieces, tools or devices used during the operative procedure that could cause damage or malfunctions are not left inside the balancer.

For safety, before starting work, maintenance, inspection and repair staff must disconnect all power sources and take all the necessary preventive safety measures.

As well as operating frequencies, the operations described below indicate the qualifications that staff must possess in order to perform the operation.

9.1.3 Replacing fuses

Some protection fuses are located on the power board (see wiring diagrams) accessible by dismantling the weight shelf). If fuses require replacement, use ones with an identical current intensity.

9.1.4 Cleaning the screen

Use a soft cloth and NON-ABRASIVE commercial glass/plastic cleaning spray or ethanol or natural detergents.

DO NOT USE:

- Organic solvents type nitro thinner
- Turpentine
- Petrol
- Trichloroethylene
- Acetone

10. Disposal



THE INSTRUCTIONS IN THIS CHAPTER ARE INDICATIVE. REFER TO THE REGULATIONS IN FORCE IN THE COUNTRY WHERE THE EQUIPMENT IS USED.

10.1 DISPOSING OF THE BALANCER

The balancer must be disposed of after dismantling the various parts.

For disposal operations, as well as wearing the Personal Protective Equipment indicated in the INSTALLATION MANUAL, refer to the instructions and diagrams in this manual. If necessary, request specific information from the manufacturer.

Once you have removed the various parts and components, separate them into the different types of materials according to the differentiated waste disposal regulations in force in the country where the machine is dismantled.

If the various components must be stored before being taken to the dump, make sure to keep them in a safe place protected from atmospheric agents in order to prevent them from contaminating the ground and the water table.

10.2 DISPOSING OF ELECTRONICS COMPONENTS



Community directive 2002/96/EC, assimilated in Italy with legislative decree n° 151 of 25th July 2005, requires electrical and electronic equipment manufacturers and users to comply with a number of obligations concerning the collection, treatment, recovery and disposal of this waste.

Please scrupulously comply with these waste disposal regulations.

Remember that abusive dumping of this waste leads to the application of the administrative penalties established by current law.

11. Spare parts

11.1 IDENTIFICATION AND ORDERING METHOD

The various parts can be identified using the exploded drawings, the electrical drawings and diagrams in the machine technical file which is archived by the Manufacturer to which a request can be made.

For off-the-shelf parts, the technical manuals or the supplier's original documents can be provided if the Manufacturer deems this to be useful.

If not supplied, this documentation is also included in the machine Technical File, archived by the Manufacturer, as regards by Ministerial Decree 2006/42/CE.

In this case, contact the Technical Service to identify the required piece.

If the required pieces are not in any position or they cannot be identified, contact the Technical Service, specifying the type of machine, its serial number and year of construction.

This information is indicated on the machine identification plate.

12. Attached documentation

If not supplied, this documentation is included in the Technical File of the machine, archived by the Manufacturer.

In this case, contact the Technical Service for detailed information concerning the machine.